



IoT-Based Damage Detection and Warning Tool for Bridges Using Pressure and Vibration Sensors

Aditya Febriansyah^{1*}, Akim M H Pardede², Milli Alfhi Syari³

^{1,2,3}STMIK Kaputama Binjai

adityafebriansyah410@gmail.com^{1*}, akimmhp@gmail.com², milli.alfhisyari@yahoo.co.id³

Abstract

Bridges are vital infrastructure that play an important role in supporting human mobility and the distribution of goods. Damage to bridges that is not detected early can pose serious risks in the form of accidents and economic losses. This study aims to design and implement a bridge damage detection and warning system based on the Internet of Things (IoT) by utilizing Load Cell sensors to detect excessive pressure/load and Gyroscope sensors to detect vibrations or tilting changes. The ESP32 microcontroller is used as the data processing center as well as a connection to the Blynk application via Wi-Fi, allowing the system to provide real-time notifications to users. Thus, this system has proven to be effective in automatically, efficiently, and cost-effectively monitoring the structural condition of bridges.

Keywords: *Bridge, IoT, ESP32, Load Cell, Gyroscope, Blynk.*

1. Background

Bridges are important infrastructure that support the movement of people and the distribution of goods across various regions. The durability and safety of bridges are crucial given the potential serious consequences in the event of damage or structural failure. However, manual monitoring of bridge conditions is often time-consuming, costly, and inefficient. In the era of modern technology, the use of the Internet of Things (IoT) as an early damage detection solution for bridges provides a more innovative and effective approach. By using pressure and vibration sensors, IoT-based systems can provide real-time information to monitor the condition of bridge structures and give early warnings to prevent serious risks.

In bridge maintenance, traditional methods for detecting damage are usually based on visual inspection or the use of technology, which is expensive and causes delays in providing results. Therefore, innovation is needed to continuously monitor the health of bridges in real-time and at a low cost. IoT technology offers solutions that can connect various sensors (such as pressure and vibration sensors) to devices that wirelessly transmit data, providing up-to-date information about the structural condition of the bridge. This IoT-based system allows for early detection of potential damage and provides faster alerts so that preventative actions can be taken more quickly. This reduces the risk of accidents and extends the service life of the bridge structure.

The application of a bridge monitoring system is essential as a tool or method to monitor the condition of the bridge, and thus the implementation of Structural Health Monitoring (SHM) is a promising way to apply strategies for detecting and characterizing damage that is useful for engineering structures in process. It is used to monitor structures, especially bridge structures. SHM can perform real-time monitoring, structural performance assessment, and identification of structural conditions.

2. Literatur Review

2.1. Detection Tool

Detection tools are a process for examining or conducting inspections on something using specific methods and techniques (Herlambang, 2021). Detection can be used for various issues, for example in damage detection systems on bridges, identifying where the system detects problems related to bridge collapse cases. The purpose of detection tools is to solve a problem in various ways depending on the method applied, resulting in a solution.

2.2. Damage Warning

A damage warning is a system, signal, or information designed to provide an early indication or notification that a damage has occurred, is occurring, or is likely to occur in a device, system, or component. This warning aims to prevent further damage, avoid total failure, and allow for timely repair or maintenance actions to be taken. Damage warnings can be conveyed through various media, such as visual

indicators (LED lights, display screens), sound (alarms, buzzers), or through digital notifications (SMS, applications, monitoring systems). This system is typically applied to electronic equipment, industrial machines, vehicles, computer systems, and various other technologies that require performance monitoring.

2.3. Bridge

Bridges are one of the important infrastructures in the lives of people, because besides serving as a connection to facilitate transportation between two or more areas separated by rivers and valleys, the presence of bridges can indirectly boost economic growth in a region (Lapis, 2013). Bridges are structural buildings used to allow people or vehicles to pass over two separate areas or spaces divided by rivers, valleys, gorges, or other physical obstacles. Therefore, a bridge is a structure built as a road crossing or as a connecting structure for transit. Based on the above research, it can be concluded that bridges are places commonly used for crossing (H. Manalip, 2018).

2.4. Internet of Things

The Internet of Things, commonly known as IoT, is an embedded system aimed at expanding the utilization of continuously connected internet connectivity. Capabilities such as data sharing, remote control, and so on, also apply to real-world objects such as food, electronics, equipment connected with sensors, and connected to networks (Susanto, 2022).

2.5. Sensor Load Cell

A load cell is a type of transducer that produces an output proportional to the load or force applied. Load cells can provide accurate measurements of force and load. Load cells are also used to convert strain in metal into variable resistance. Through mechanical adjustments, strength detects the deformation of a strain gauge. Strain gauges measure deformation as a change in electrical resistance, which is a measure of strain and thus the applied strength. A load cell typically consists of four strain gauges in a Wheatstone bridge configuration. Load cells of a single strain gauge (quarter bridge) or two strain gauges are also available. The output signal is usually in the order of a few millivolts and requires amplification by an instrumentation amplifier before it can be used. The output from the transducer can be enhanced for calculations.

2.6. Sensor Gyroscope

A gyroscope is a sensing device used to measure or maintain orientation based on the principle of angular momentum conservation. More specifically, a gyroscope can detect and measure rotational movement or changes in the orientation of an object with respect to an inertial reference frame. Gyroscopes operate based on the principle of the Coriolis effect, where a moving object in a rotating system experiences a force that is perpendicular to the direction of rotation and the direction of the object's movement. By utilizing this principle, gyroscopes can measure angular velocity with high accuracy. The use of gyroscopes is very broad, ranging from simple applications like the auto-rotate feature on smartphones to advanced navigation systems in airplanes and rockets. Its ability to detect orientation and rotational movement makes the gyroscope a key component in various modern technology devices.

2.7. ESP32

The ESP32 is a microcontroller introduced by Espressif Systems, which is the successor to the ESP8266 microcontroller. This microcontroller has a built-in WiFi module in the chip, making it very suitable for creating Internet Of Things application systems (Savitri, 2022). The ESP32 is the name of the microcontroller designed by the Shanghai-based company, Espressif Systems. The ESP32 offers a standalone WiFi networking solution as a bridge from existing microcontrollers to WiFi networks. The ESP32 uses a dual-core processor that runs on Xtensa LX16 instructions (Kusumah, 2019).

3. Design And Analysis

3.1. Research Methodology

The method used in this research is the design method (prototyping). This method includes several main stages, namely:



Fig.1: Research Methodology

3.2. Control System Flowchart

The design of this tool begins with the creation of a flowchart to facilitate the planning and development of the program on the microcontroller. The creation of a flowchart is useful for simplifying the understanding of the working process of the tool. The program flowchart from this research includes the control system of the tool's operation, which can be seen in Figure III.2:

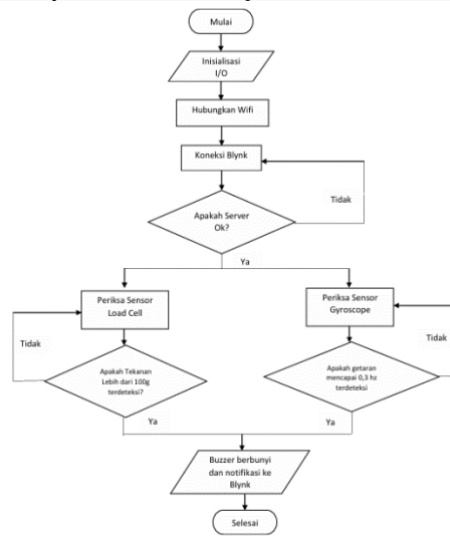

Fig.2: Control System Flowchart

The following is an explanation of the Flowchart for the Control System for detecting damage on bridges as follows:

1. Start.
2. Initialize Input/Output.
3. Connect the device to the internet such as Wi-Fi, etc.
4. Also connect to Blynk.
5. Is the server okay? If yes, then proceed to check both sensors. If not, return to the initial connection.
6. Process detection of pressure on excessive load, and detect on the bridge if there is excessive load and vibration, then the Buzzer sounds and provides a notification to Blynk.
7. Next, if not detected, perform a check on the sensors.
8. Finished.

3.3. Block Diagram Series

The design of the block diagram circuit is the design of electronic components in such a way that it has the desired function. Generally, the planning of the tool design is as follows:

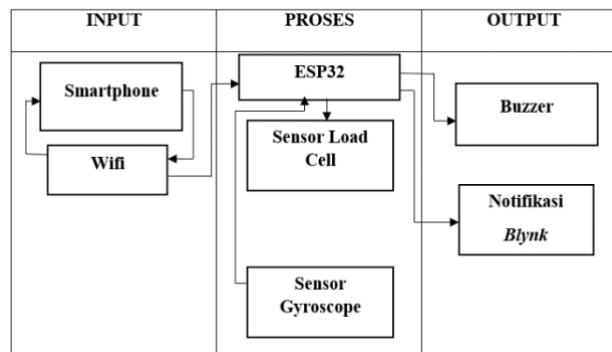

Fig.3: Blok Diagram Series

The block diagram in figure III.2 shows that the first process is to connect the hardware used such as a smartphone or computer, to Wi-Fi, in the next process the sensor detects load and vibration. Then, the data from the sensor is sent to the ESP32 which will later command the Buzzer to sound as a danger alarm and subsequently a notification is sent via Blynk. Here is the explanation:

1. Smartphone and internet network are used as input.
2. ESP32 as the microcontroller.
3. Load Cell Sensor to measure weight.
4. Gyroscope Sensor is used as a vibration detector.
5. Buzzer functions as a danger alarm.
6. Blynk notification as output on the device.

3.4. Electronic Circuit Scheme

Schematic of an electronic circuit using ESP32 as the microcontroller that receives data from sensors. The ESP32 design functions as a connection between hardware and the internet. The output of the ESP32 will be connected to a Buzzer to send a danger signal. Below is a description of the schematic of the IoT bridge damage detection electronic device:

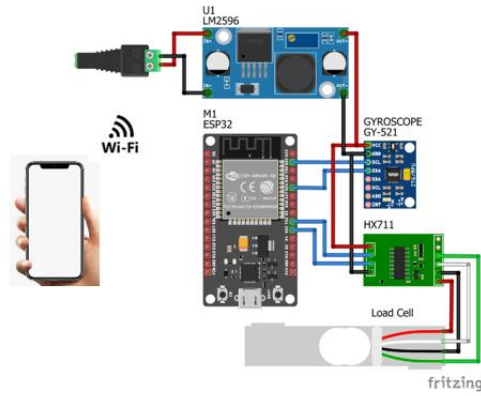

Fig.4: Electronic Circuit Scheme

4. Results and Discussion

In this chapter, the author outlines and explains the research results by conducting tests. The tests to be conducted are software and hardware tests. Here is the explanation:

4.1 Software Testing

To conduct the program test, the initial steps in this experiment are as follows:

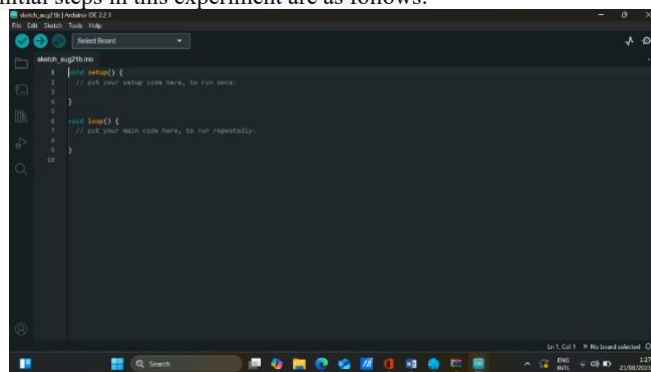

Fig.5 : Initial Display of Arduino IDE

4.2 Hardware Testing

After all the programs are typed, design the hardware as shown in Figure IV.2.

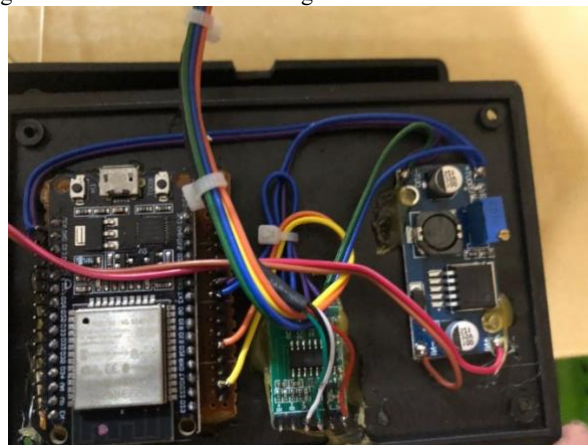

Fig.6 : Design of ESP32 Hardware to Gyroscope and LoadCell sensors

Next, the test for the device's activity, based on the indicators in the active/on circuit:

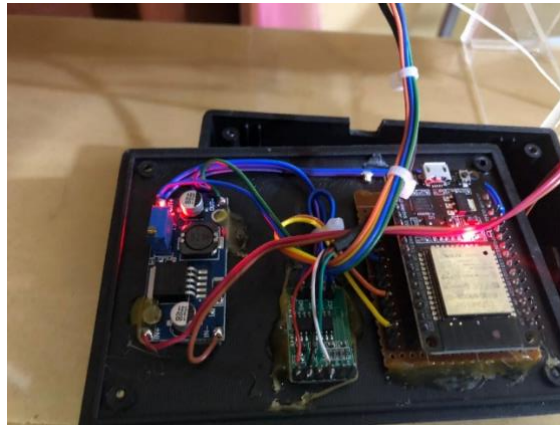

Fig. 7 : Position of the tool when active

4.3 Blynk Testing

In this Blynk testing, we create a new template with widgets as shown in the image below:

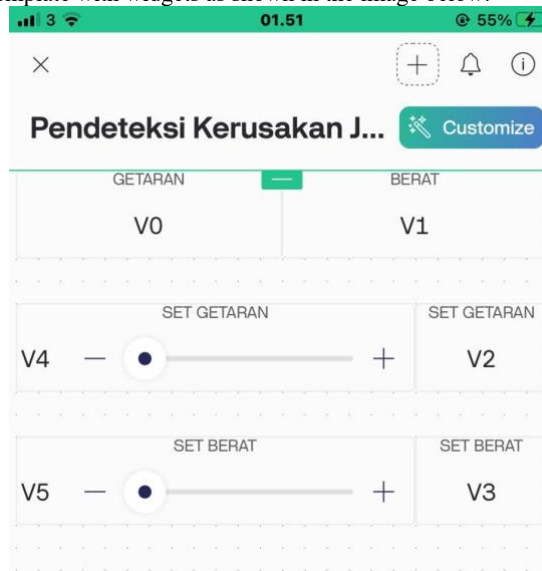

Fig . 8: Blynk Display

After the program has been fully typed, the next step is to input the program code into the circuit by clicking the Bar menu on the Arduino IDE and then clicking upload, with the note that the Board and Port in the Arduino IDE Bar menu are already set. Next, wait a moment until the upload process is complete, then the program that has been uploaded will automatically be saved to the microcontroller.

4.4 Implementation of Overall Testing Using a Bridge Prototype With Load Cell and Gyroscope Sensors Connected to Blynk

The implementation of this testing is carried out to determine the performance of the components that will be used in this thesis, with the output being Blynk, which will control and detect load and vibration on the bridge by sending sensor data generated from pressure and vibrations with notifications sent in Real-Time. By being connected to the internet, Blynk can receive data sent by the microcontroller. This experiment was conducted by placing a load on the bridge with a maximum limit that has been programmed, as a load test and for vibration testing and notification when vibration occurs. The next step was to apply vibration to the bridge. And the notification trial on Blynk in real time. After all the circuits were completed in the "IoT-Based Damage Detection and Warning System for Bridges Using Pressure and Vibration Sensors," here is the image of the successful test of pressure and vibration detection for bridge damage detection using IoT in the image IV.5 below:

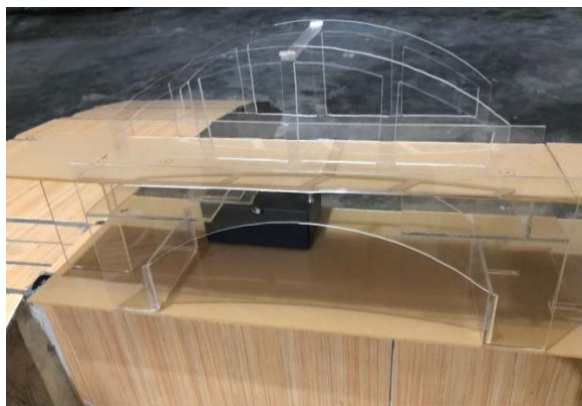

Fig. 9: Overall Circuit Results

5. Conclusion

Based on the results of the research and discussion that have been conducted, several conclusions can be drawn as follows:

1. An IoT-based bridge damage detection and warning system has been successfully designed using the ESP32 microcontroller connected with Load Cell and Gyroscope sensors. This system is capable of monitoring the condition of the bridge structure in real-time and providing early warnings in the form of a buzzer alarm and notifications via the Blynk application when excessive loads or abnormal vibrations are detected.
2. The integration of pressure sensors (Load Cell) and vibration sensors (Gyroscope) has proven effective in detecting physical changes in the bridge structure. Test results show that the combination of these two sensors can provide sufficiently accurate data to identify indications of damage or decline in bridge performance at an early stage.

References

- [1.] Al Fani, Handri, et al. "Perancangan Alat Monitoring Pendeteksi Suara di Ruang Bayi RS Vita Insani Berbasis Arduino Menggunakan Buzzer." *Jurnal Media Informatika Budidarma* 4.1 (2020): 144.
- [2.] Bawotong, Vike T., Dringhuzen J. Mamahit, and Sherwin RUA Sompie. "Rancang bangun uninterruptible power supply menggunakan tampilan LCD berbasis mikrokontroler." *Jurnal Teknik Elektro dan Komputer* 4.2 (2015): 1-7.
- [3.] Efendi, Yoyon. "Internet of Things (IOT) sistem pengendalian lampu menggunakan Raspberry PI berbasis mobile." *Jurnal Ilmiah Ilmu Komputer Fakultas Ilmu Komputer Universitas Al Asyariah Mandar* 4.1 (2018): 19-26.
- [4.] Herlambang, Hery, Jaka Suwita, and Beby Tiara. "Analisa Dan Perancangan Sistem Pendeteksi Plagiarisme Skripsi Pada Stmik Insan Pembangunan Menggunakan Metode Cosine Similarity." *Insan Pembangunan Sistem Informasi dan Komputer (IPSIKOM)* 9.1 (2021).
- [5.] Kusumah, Hendra, and Restu Adi Pradana. "Penerapan trainer interfacing mikrokontroler dan internet of things berbasis esp32 pada mata kuliah interfacing." *Journal Cerita* 5.2 (2019): 120-134.
- [6.] Lapis, Julfrenly Onding, et al. "Analisis Kestabilan Pondasi Jembatan Studi Kasus: Jembatan Essang-Lalue." *Jurnal Sipil Statik* 1.11 (2013): 730-744.
- [7.] Manalip, H., and Banu D. Handono. "Perencanaan Balok Girder Profil I pada Jembatan Prestressed dengan Variasi Bentang." *Jurnal Sipil Statik* 6.2 (2018): 67-74.
- [8.] Muhammad, Rayhan, Setyorini Setyorini, and Seno Adi Putra. "Wireless Sensor Network Untuk Menganalisis Perilaku Jembatan Single Degree Of Freedom Dengan Menggunakan Metode Hilbert Huang Transform." *eProceedings of Engineering* 8.2 (2021).
- [9.] Nizam, Muhammad Nizam, Haris Yuana, and Zunita Wulansari. "Mikrokontroler ESP 32 sebagai alat monitoring pintu berbasis web." *JATI (Jurnal Mahasiswa Teknik Informatika)* 6.2 (2022): 767-772.
- [10.] Saktiawan, Bima. "RANCANG BANGUN SISTEM MONITORING JEMBATAN TIMBANG BERBASIS IoT."
- [11.] Satria, Syach Dewa Dinasti, and Rini Puji Astutik. "PERANCANGAN SISTEM MONITORING KETAHANAN JEMBATAN BERBASIS IOT (INTERNET OF THINGS)." *Jurnal Informatika dan Teknik Elektro Terapan* 13.1 (2025).
- [12.] Savitri, Chyntia Eka, and Nina Paramytha. "Sistem monitoring parkir mobil berbasis mikrokontroler ESP32." *Jurnal Ampere* 7.2 (2022): 135-144.
- [13.] Setiawan, Hasbi Ade, and Tri Rijanto. "Rancang Bangun Sistem Kontrol Pengisian Air Minum Dalam Kemasan Menggunakan Arduino Uno Dengan Sensor Load Cell." *Jurnal Teknik Elektro* 8.3 (2019).
- [14.] Soetjipto, Jojok Widodo. *Model Probabilistik Prediksi Keruntuhan Jembatan Berbasis Hibrid Bayesian-System Dynamics*. Diss. Institut Teknologi Sepuluh Nopember, 2020.
- [15.] Suhaidi, Mustazzihim. "Penerapan Internet Of Thing (Iot) dalam Perancangan Aplikasi Pengaman Sepedamotor Berbasis android." *Jurnal Ilmu Komputer dan Bisnis* 10.1 (2019): 2167-2172.
- [16.] Susanto, Fredy, Ni Komang Prasiani, and Putu Darmawan. "Implementasi Internet of Things Dalam Kehidupan Sehari-Hari." *Jurnal Imagine* 2.1 (2022): 35-40.
- [17.] Swargara, Stana Edro, Setyorini Setyorini, and Seno Adi Putra. "Pemanfaatan WSN (Wireless Sensor Network) Untuk Menganalisis Perilaku Jembatan Menggunakan Metode Ibrahim Time Domain." *eProceedings of Engineering* 8.2 (2021).
- [18.] Tamba, Saut P., et al. "Pengontrolan lampu jarak jauh dengan nodemcu menggunakan blynk." *Jurnal Teknikom (Teknik Informasi dan Komputer)* 2.1 (2019): 93-98.
- [19.] Widayatno, Arwan Hanif. "Penggunaan Teknologi dalam Monitoring Ketahanan Struktur Jembatan."