



Optimization of the Automatic Bell System of STMIK Kaputama with Time Control Based on Smartphone Using Nodemcu

Arya Prayoga^{1*}, Achmad Fauzi², I Gusti Prahmana³

¹²³STMIK Kaputama Binjai

aryaprayoga644@gmail.com^{1*}, fauzyriva88@gmail.com², igustiprahmana4@gmail.com³

Abstract

This research aims to design and implement an Internet of Things (IoT)-based automatic bell system integrated with a smartphone using the ESP32 microcontroller. The background of this study is the limitation of the previous automatic bell system at STMIK Kaputama, which had unclear sound quality and lacked flexibility in scheduling. The developed system utilizes the RTC DS3231 for time management, the DFPlayer Mini for audio playback, and the Blynk application as a remote control interface. The research method includes hardware design, software development, and system functionality testing. The results show that the system operates according to the class schedule with clearer sound output, can be controlled via a smartphone, and supports the concept of an efficient and modern smart campus. Therefore, this system can be an effective solution to optimize the time management of academic activities on campus.

Keywords: Automatic Bell, ESP32, IoT, Blynk, RTC, Smartphone.

1. Background

In an era of advancing technology, system automation has become one of the solutions to improve efficiency and comfort in various aspects of life. One example of widely used automation applications is in time management systems, such as school bell systems. The bell system used at the Kaputama School of Information Management and Computer Science (STMIK) is currently using an automatic bell; however, the sound quality is not very clear and good. Therefore, innovation is needed in designing an automatic bell system with significantly clearer sound features.

The development of a smartphone-based bell system with time control using NodeMCU is motivated by the need to overcome the limitations of low and unclear sound which is still widely applied in various educational institutions, including STMIK Kaputama. Manual systems are often inflexible, prone to human error, and require continuous supervision. In this context, Internet of Things (IoT) technology offers a solution that can connect hardware with software in real time, allowing for more efficient bell system management that can be accessed via smartphones. With IoT, users can remotely control and monitor the bell system, optimize time settings, and minimize manual interventions that are prone to errors.

The Internet of Things (IoT) based automatic bell system is designed to improve the efficiency of bell operation in educational institutions by utilizing the latest technology. This research aims to develop a system that can automatically control the bell according to the class schedule and allow remote control through a mobile application using the Blynk platform. This system is built using ESP32 as the main microcontroller, DFPlayer Mini module for audio playback, and RTC DS1307 for time management (Ali Imran, 2024).

2. Literatur Review

2.1. Optimization

Optimization is the action of making something run as well as possible, or in other words, making it the best. This process is part of the efforts to improve the development system. Optimization means achieving the desired results, so optimization can be interpreted as achieving outcomes that align with expectations in an efficient and effective manner. From the explanation above, we can conclude that optimization is a method or step to encourage the progress of development. (Pardede, 2022).

Optimization is rooted in the word optimal, which means the best or highest. Meanwhile, optimization is a process to improve or elevate the achievement of desired targets according to specified criteria. Optimization is a step to find the best solution among various available

alternative solutions. This process is carried out by maximizing the objective function without violating existing constraints. By applying optimization, a system can enhance its efficiency, such as increasing profit, reducing required time, and so on. (Hidayat, 2022).

2.2. Bell

The bell serves as a sign that an activity at school begins or ends. Fifteen to twenty years ago, the use of electric bells was still done manually, with someone in charge or a teacher pressing it. Now, school bells have evolved to be more modern, including automatic features, so that staff or teachers no longer have to press the bell every time they enter, during breaks, to change classes, or when going home. Many studies on school bells have also been conducted, such as those discussing bells that use computers. The computer functions as a timer for when the bell rings. The signal coming from the computer is used to control the relay. When the relay is active, the speaker will function (Ali Imran, 2024).

2.3. Smartphone

A smartphone is a device that enables communication and also functions as a PDA (Personal Digital Assistant) with capabilities similar to a computer. One of the distinctive features of a smartphone is the presence of application software. The application software available on smartphones aims to enhance efficiency and support daily activities. Another characteristic of smartphones is their ability to connect to the internet. Smartphones can be used to access the web or the internet, and the display of content available in their browsers is almost equivalent to when we use a computer to access the web. Some examples of browsers found on smartphones are Opera Mobile, SkyFire Mobile, and IE Mobile. (Mandias, 2017).

2.4. ESP32

ESP32 is a WiFi module that functions as an additional microcontroller similar to Arduino, allowing direct connection to a WiFi network to establish a TCP/IP connection. Additionally, this module is based on SOC (Single on Circuit), which enables the use of this device without requiring an additional microcontroller. This module requires about 3.3V of power and has three types of WiFi modes: Station, Access Point, and a combination of both. The ESP32 has a fairly large RAM, making it easy to handle complex applications, making it very suitable for projects that require strong processing capabilities. With an integrated WiFi module, the ESP32 allows for internet connectivity, opening possibilities for IoT projects that require stable connectivity.

2.5. Internet of Things

The Internet of Things (IoT) is an idea aimed at maximizing the benefits of always-on internet connectivity. Fundamentally, IoT refers to uniquely identifiable objects as virtual representations within an internet-based network. The working principle of IoT involves communication between interconnected machines, regardless of distance. To realize this working principle of IoT, the internet serves as a connector between interactions among machines, while users act as controllers and monitors of the functions of these devices directly. (Nurul Hidayati, 2019).

2.6. Speaker

A speaker is a transducer that converts electrical signals into audio frequencies (sound) by vibrating its membrane-shaped components to vibrate the air, thus creating sound waves. A speaker, also known as a loudspeaker, is a device that transforms electrical signals into audio frequencies (sound) through the vibration of membrane-shaped components to vibrate the air, resulting in sound waves that reach the eardrum and can be heard as sound (Irwan, 2023).

2.7. Relay

A relay is a switch that is operated through electricity and is an electromechanical component that has two main parts, namely an electromagnet (coil) and a mechanical part (switch contacts). The principle used in a relay is electromagnetic, which is used to move the switch contacts so that a small current (low power) can conduct electricity at a higher voltage. In a relay, there is usually a coil with an iron core, and when the coil is energized, it becomes a magnet and pulls the contacts together, resulting in contact. When the contacts are connected, the current will flow (Budiyanto, 2020).

2.8. Jumper Cable

Jumper cables are electrical cables used to connect components on a breadboard without the need for soldering. Jumper cables typically have connectors or pins at each end. The connector that is used for insertion is called a male connector, and the connector that is used to be inserted into is called a female connector. Jumper cables are divided into 3 types: Male to Male, Male to Female, and Female to Female (Fathulrohman, 2019).

3. Design And Analysis

3.1. Research Methodology

The method used in this research is the design method (prototyping). This method includes several main stages, namely:

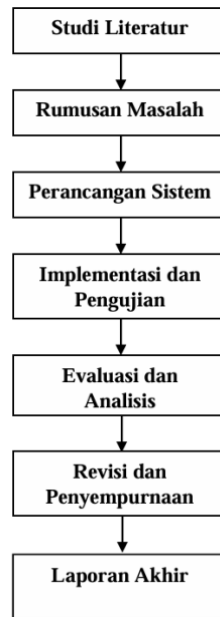

Fig.1 : Research Methodology

3.2. Control System Flowchart

The design of this tool begins with the creation of a flowchart to facilitate the planning and development of the program on the microcontroller. The creation of a flowchart is useful for simplifying the understanding of the working process of the tool. The program flowchart from this research includes the control system of the tool's operation, which can be seen in Figure III.2:

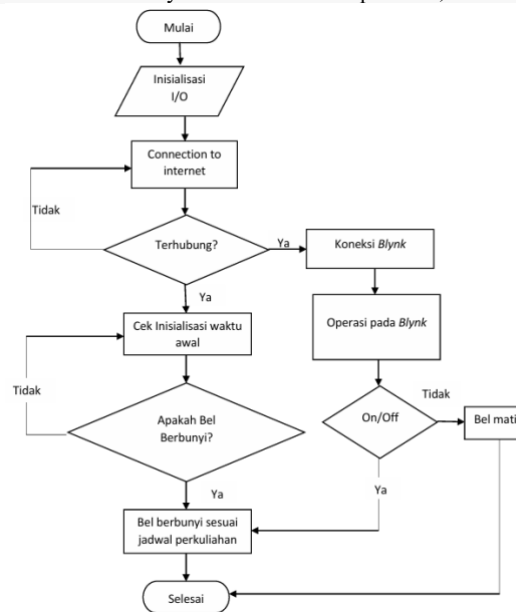

Fig. 2: Control System Flowchart

The following is an explanation of the flowchart for the automatic bell control system as follows:

1. Start.
2. Initialize Input/Output.
3. Connect the hardware to the internet such as wifi, etc.
4. Connected? If not connected, return to the initial connection, if connected then perform the initial initialization check.
5. Does the bell ring? If yes, then the bell will ring according to the class schedule, but if no, check the initial time initialization.
6. Then connect to Blynk, Manual process, On/Off, if on then the bell rings. And if off, the bell is off.
7. Done.

3.3. Block Diagram Series

The design of the block diagram circuit is the design of electronic components in such a way that it has the desired function. Generally, the planning of the tool design is as follows:

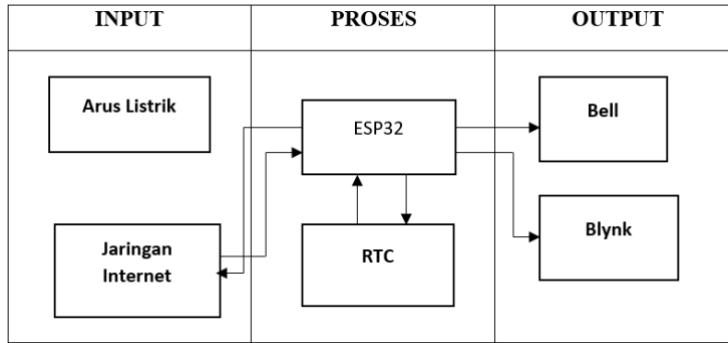

Fig.3 : Blok Diagram Series

The block diagram sequence in Figure III.2 shows that the first process is to connect the hardware used, such as a smartphone or computer, to Wi-Fi. In the next process, the RTC works with the specified schedule data. Then, the data results from the RTC are sent to the ESP32, which will then instruct the Bell to ring. Subsequently, a notification will indicate the on/off status of the device.

3.4. Electronic Circuit Scheme

Schematic of an electronic circuit using ESP32 as a microcontroller that receives data from RTC. The design of the ESP32 serves as a connection between hardware and the internet. The output of the ESP32 will be connected to a Bell to make it ring. Below is an illustration of the optimal automatic bell circuit scheme:

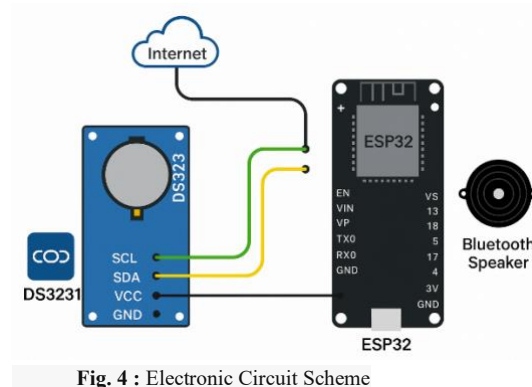

Fig. 4 : Electronic Circuit Scheme

4. Results And Discussion

In this chapter, the author outlines and explains the research results by conducting tests. The tests to be conducted are software and hardware tests. Here is the explanation:

4.1 Software Testing

To conduct the program test, the initial steps in this experiment are as follows:

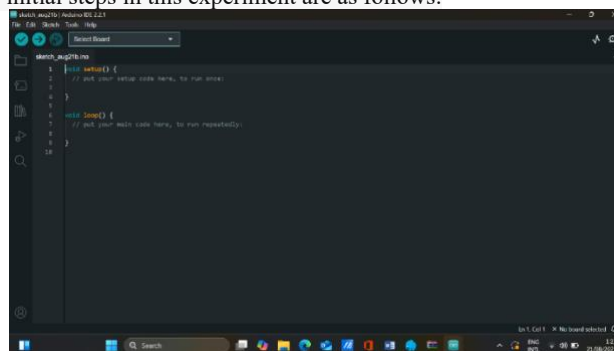

Fig.5 : Initial Display of Arduino IDE

4.2 Hardware Testing

After all the programs are typed, design the hardware as shown in Figure 6.

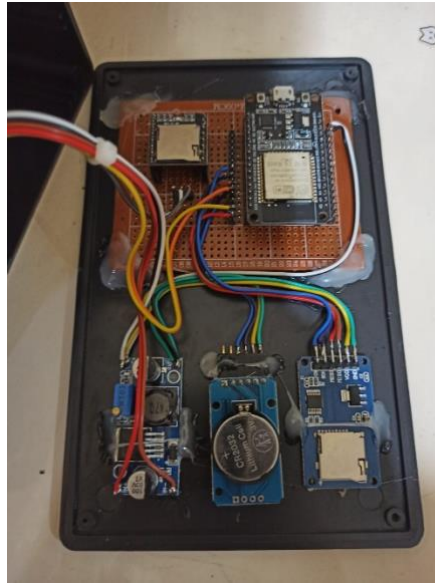

Fig. 6: ESP32 Hardware Design with Other Components

Next, the test for the device's activity, based on the indicators in the active/on circuit:



Fig.7 : Position of the tool when active

4.3 Blynk Testing

In this Blynk testing, we create a new template with widgets as shown in the image below:

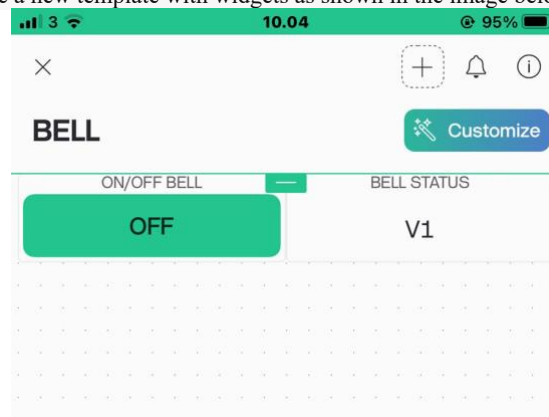

Fig. 8: Blynk Display

After the program has been fully typed, the next step is to input the program code into the circuit by clicking the Bar menu on the Arduino IDE and then clicking upload, with the note that the Board and Port in the Arduino IDE Bar menu are already set. Next, wait a moment until the upload process is complete, then the program that has been uploaded will automatically be saved to the microcontroller.

4.4 Implementation of Overall Testing Using RTC and ESP32 Connected with Blynk

The implementation of this testing is carried out to determine the performance of the components that will be used in this thesis, with the output being a bell sound, indicating that the bell has been successfully implemented. By being connected to the internet, Blynk can receive data sent by the microcontroller. This experiment is conducted by testing sample schedule data taken from STMIK Kaputama Binjai. As a trial, the next step is to activate the bell first, then the bell will activate according to the input schedule. After all the circuits have been designed in "Optimization of the Automatic Bell System at STMIK Kaputama with Smartphone-Based Time Control Using NodeMCU," the following is an image of the success of the automatic bell testing with the class schedule using NodeMCU in Figure IV.5 below:



Fig. 9 : Overall Circuit Results

5. Conclusion

Based on the results of the research and implementation that have been carried out, the following conclusions can be drawn:

1. The automatic bell system based on ESP32 and RTC controlled through the Blynk application has been successfully designed and implemented according to the course schedule at STMIK Kaputama.
2. This system has successfully been developed into a feature with better sound. This system is also capable of improving the efficiency of class scheduling by minimizing human error that often occurs in manual systems.

References

- [1.] Affandy, Andy Lukman. "Rancang Bangun Bel Sekolah Otomatis Berbasis Personal Computer (PC)." *Jurnal IT* 8.3 (2017): 194-206.
- [2.] Agung, Raka, Ngurah Janardana, and Ferry Ardiansyah. "Rancang Bangun Bel Sekolah Otomatis Berbasis Mikrokontroler AVR ATMEGA8." *Teknologi Elektro* 10.2 (2011): 11-17.
- [3.] As'ad, Ali, Nuzul Hikmah, and Ahmad Izzuddin. "Rancang Bangun Bel Sekolah Otomatis Berbasis Mikrokontroler Arduino Uno Menggunakan Df Player." *Energy: Jurnal Ilmiah Ilmu-Ilmu Teknik* 11.1 (2021): 58-68.
- [4.] Budiyanto, Almira, Genta Bayu Pramudita, and Sisdamanto Adinandra. "Kontrol relay dan kecepatan kipas angin direct current (DC) dengan sensor suhu LM35 berbasis internet of things (IoT)." *Techné: Jurnal Ilmiah Elektroteknika* 19.1 (2020): 43-54.
- [5.] Fahreza, Muhammad Fadlan, Devri Suherdi, and Rina Mahyuni. "Rancang Bangun Bel Otomatis pada sekolah Menggunakan Modul RTC dan Modul Mp3." *Jurnal Sistem Komputer Triguna Dharma (JURSIK TGD)* 2.6 (2023): 307-315.
- [6.] Fajriyah, Latifatul. *Analisis Pengaruh Cone Displacement terhadap Error Pengukuran dan Simulasi Respon Frekuensi Driver Speaker dan Dodecahedron Speaker*. Diss. Institut Teknologi Sepuluh Nopember, 2023.
- [7.] Hasby, Fachrul, et al. "Rancang Bangun Bel Otomatis pada STIKOM Tunas Bangsa Berbasis Arduino dengan Output Suara." *Bulletin of Computer Science Research* 1.3 (2021): 63-70.
- [8.] Hidayat, Asep, and M. Irvanda. "Optimalisasi penyusunan dan pembuatan laporan untuk mewujudkan good governance." *Jurnal Ilmiah Hospitality* 11.1 (2022): 281-290.
- [9.] Irwan, Adi, and Agus Kiswanton. "Membuat Speaker Bluetooth Helm Dengan Modul Penerima Bluetooth 4.1." *Jurnal Pengabdian Siliwangi* 9.1 (2023).
- [10.] Linarta, Arie, and Nurhadi Nurhadi. "Aplikasi Bel Sekolah Otomatis Berbasis Arduino Dilengkapi Dengan Output Suara." *Informatika* 10.2 (2019): 1-7.
- [11.] Mandias, Green Ferry. "Analisis pengaruh pemanfaatan smartphone terhadap prestasi akademik mahasiswa Fakultas Ilmu Komputer Universitas Klabat." *Cogito Smart Journal* 3.1 (2017): 83-90.
- [12.] Pardede, Piki Darma Kristian, Desi Januari Tafonao, and Erwin Edielis Buulolo. "Optimalisasi penggunaan dana desa dalam pembangunan desa lolosoni kecamatan gomo kabupaten nias selatan 2019/2020." *Jurnal Governance Opinion* 6.2 (2022): 78-89.
- [13.] Ramaita, R., A. Armaita, and Pringga Vandelis. "Hubungan ketergantungan smartphone dengan kecemasan (nomophobia)." *Jurnal Kesehatan* 10.2 (2019): 289846.
- [14.] Rizal, Adhi, et al. "Analisis Perbandingan Kecepatan Transfer Data Dengan Kabel USB TIPE A dan USB TIPE C." (2019): 144-148.
- [15.] Tamba, Saut P., et al. "Pengontrolan lampu jarak jauh dengan nodemcu menggunakan blynk." *Jurnal Teknikom (Teknik Informasi dan Komputer)* 2.1 (2019): 93-98.
- [16.] Wahyuningtyas, Eka Santi, Rendy Munadi, and Sussi Sussi. "Aplikasi Smart Parking Berbasis Android Menggunakan Sensor Radio Frequency Identification (rfid) Di Universitas Telkom." *eProceedings of Engineering* 6.2 (2019).
- [17.] Wildan, Wildan, Agus Romadhona, and Ayu Hernita. "Irrigation Monitoring Control Untuk Tanaman Hidroponik Dengan Metode Nft Menggunakan Arduino Berbasis SMS Gateway." *E-JURNAL JUSITI: Jurnal Sistem Informasi dan Teknologi Informasi* 9.1 (2020): 77-85.
- [18.] Yosefariko, Yosefariko, Tengku A. Riza, and Yuyu Wahyu. "Perancangan Dan Realisasi Antena Mikrostrip Dual Band Menggunakan Slot Berbentuk U Untuk Aplikasi Wifi." *eProceedings of Engineering* 2.2 (2015).