



# Car Distribution Of Lightweight File Delivery Using IoT

Anggi Muhammad Tanjung<sup>1\*</sup>, A M H Pardede<sup>2</sup>, Milli Alhfi Syari<sup>3</sup>

<sup>123</sup> Informatics Engineering, STMIK Kaputama  
Jl. Veterans No. 4A-9A, Binjai, North Sumatra, Indonesia  
[anggimuhammad516@gmail.com](mailto:anggimuhammad516@gmail.com)<sup>1\*</sup>, [akimmhp@live.com](mailto:akimmhp@live.com)<sup>2</sup>, [milli.fhisya@gmail.com](mailto:milli.fhisya@gmail.com)<sup>3</sup>

---

## Abstract

A lightweight file lifter car distribution device using Iot has been designed. This robot system uses the Node MCU ESP8266 microcontroller where the Node MCU ESP8266 functions as a data processor, and also a WI-FI network receiver emitted by a WI-FI network system. This robot car system uses a control system using an Android smartphone to control the movement of the wheels, this robot car uses a WI-FI network communication system so that the robot car system and Android smartphone can be connected, in this robot car system it uses a DC motor rotation direction drive driver which is The driver functions to move the direction of rotation of the DC motor on the wheels of the robot car. The power supply for this robot uses 3 3.7 Volt Li-Ion batteries which are arranged in series to get a 12 volt voltage, the 12 volt battery voltage goes first to the 7805 regulator IC circuit to get an output voltage of 5 volts, 5 volts voltage. this is what functions to supply the robot system so that it can be operated

*Keywords:* Node MCU ESP8266, Smartphone Android, WI-FI.

---

## 1. Introduction

Currently the development of technology can be categorized very rapidly. Various kinds of technology were born and created to help human life. For example, a smartphone is a cellphone that has advanced features that can help human activities. As another example of technological developments, namely a robot technology that is currently widely used by humans in everyday life. A robot is a tool that can perform physical tasks, either using human control, or using predefined programs. For now, offices and schools still use humans to send files to a room where things like that are less effective and efficient, therefore this robotic car is made to facilitate human work in distributing files from one place to another using a smartphone control and system. IOT (Internet Of Things) to make the job of sending files easier and more efficient. Various robots have been developed and made to fulfill human desires. The rapid development in robot manufacturing makes students want to learn and develop their knowledge of robotics, from prototypes to actual systems. In the previous study, research was carried out with the title Design and Build of a Simple Control Car Robot using Android-Based Arduino System, which was made by David Setiawan from the Faculty of Engineering, Lancang Kuning University. Remote car toys are still in great demand by children, usually the age of these toys is not long because physical or electronic damage [1].

## 2. Previous Research

### 2.1 Robot

Robot is a mechanical device that can perform physical tasks. Some use human supervision and control, or use pre-defined programs (artificial intelligence). Classic robots have been around since ancient Greece. Until now, robots continue to be developed so that their existence really helps humans in doing routine and heavy work, or even as an entertainer. In general, a robot can be defined as a mechanical device capable of doing human work or behaving like a human [2].

### 2.2 Microcontroller

A microcontroller is a functional computer system on a chip that includes a processor core, memory (a small amount of RAM, program memory, or both), and input-output equipment. In other words, a microcontroller is a digital electronic device that has input and output as well as control with a program that can be written and deleted in a special way, how the microcontroller actually reads and writes data. As an example, imagine yourself when you start learning to read and write, when you are able to do that you can read any writing, be it books, short stories, articles and so on, and you can also write things the other way around. Likewise, if you are proficient at reading and writing data, you can create a program to create an automatic control system using a microcontroller according to your wishes [3].

### 2.3 NODEMCU ESP8266

Node MCU is basically a development of ESP 8266 with e-Lua based firmware. The Node MCU is equipped with a micro USB port which functions for programming and power supply. Apart from that, Node MCU is also equipped with push buttons, namely reset and flash buttons. Node MCU uses the Lua programming language which is a package from esp8266. The Lua language has the same logic and programming structure as C, but the syntax is different. If you use the Lua language, you can use the Lua loader and Lua uploader tools. Apart from the Lua language, Node MCU also supports the Arduino IDE software by making a few changes to the board manager on the Arduino IDE. Before being used, this board must be flashed first so that it supports the tools to be used. If using the Arduino IDE, use the appropriate firmware, namely the output firmware from Ai-Thinker which supports AT Command. To use the firmware loader tool that is used is the Node MCU firmware [4].

### 2.4 WI-FI

"Wireless Fidelity" or abbreviated WiFi is a technology that uses radio waves to connect devices (PCs, laptops, smartphones) to a computer network. Or the definition of WiFi is a technology that uses radio waves so that computers can access the internet. For a WiFi connection, a wireless adapter (without cables) is needed to build a hotspot, so that with a certain coverage, users can access the internet. In terms of connectivity, WiFi uses wireless to connect to user devices, which generally use frequencies from 2.4GHz to 5GHz. In the beginning, WiFi was only used as a wireless device on a LAN (Local Area Network) network, but along with technological developments and user needs, now it can also be used to access the internet network [5].

### 2.5 Mobile Communications

Mobile can be defined as an electronic device that is used for two-way radio telecommunications through a cellular network of base stations known as cell sites. A cell phone is different from a cordless phone, which only offers telephone service over a limited range via a single base station attached to a fixed land line, for example within a home or office. In addition to being a telephone, a modern cell phone also supports many additional services and accessories, such as SMS (or text) messaging, e-mail, Internet access, games, Bluetooth and infrared short-range wireless communication, cameras, MMS messaging, radio players, MP3 and GPS. Low-end mobile phones are often referred to as feature phones, while high-end mobile phones that offer more advanced computing capabilities are referred to as smartphones [6].

### 2.6 Androids

Android is a Linux-based operating system for mobile phones such as smartphones and tablet computers. Android provides an open platform for developers to create their own applications for use by a variety of mobile devices. Initially, Google Inc. buys Android Inc., a newcomer that makes software for cell phones. Then to develop Android, the Open Handset Alliance was formed, a consortium of 34 hardware, software, and telecommunications companies, including Google, HTC, Intel, Motorola, Qualcomm, T-Mobile, and Nvidia [7].

### 2.7 L298N drivers

The L298N motor driver is the most widely used or used DC motor driver module in the world of electronics which is used to control the speed and direction of DC motor rotation. The L298 IC is an H-bridge type IC capable of controlling inductive loads such as relays, solenoids, DC motors and stepper motors. The L298 IC consists of logic transistors (TTL) with nan gates which function to make it easier to determine the direction of rotation of a dc motor or stepper motor.

### 2.8 Li-Ion Batteries (Lithium-Ion)

Li-Ion (Lithium-Ion) type batteries are the most widely used type of battery in portable electronic equipment such as digital cameras, cellphones, video cameras or laptops. Li-Ion batteries have a high cycle life and are also about 30% lighter and provide about 30% higher capacity when compared to Ni-MH Batteries. Self-discharge ratio is about 20% per month. Li-Ion batteries are more environmentally friendly because they do not contain the harmful substance Cadmium. Just like Ni-MH (Nickel-Metal Hydride) batteries, although they do not contain the harmful substance Cadmium, Li-Ion batteries still contain a small amount of harmful substances that can damage human health and the environment, so they need to be recycled and should not be thrown away. in any place

### 2.9 Regulators

The regulator is a series of regulators or regulators of the output voltage of a power supply so that the effects of rising or falling grid voltage do not affect the power supply voltage so that it becomes stable. A rectifier circuit is fine if the voltage ripple is small, but there are stability problems. If the PLN voltage increases/decreases, then the output voltage will also increase/decrease. Like the rectifier circuit above, if the current is getting bigger it turns out that the output dc voltage also drops. For some applications this voltage change is quite disturbing, so an active component is needed that can regulate this output voltage to be stable [3].

## 3. Research methodology

The implementation method in this study is generally divided into 5 stages as shown in the following diagram:

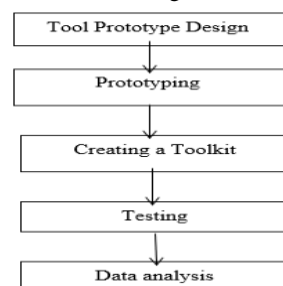

Figure 1: Research Workflow

### 3.1 Device Design Requirements to be used

The device design requirements include:

1. USB data cable and rainbow cable
2. DC motors
3. NodeMCU ESP8266 microcontroller
4. L298N Motor Drivers
5. Battery
6. Smartphones
7. Glue
8. Tin
9. PCB board
10. Some bolts and nuts

### 3.2 Requirements Software (Software) to be used

The software needed in the Lightweight File Lift Car Distribution Using IOT is the MS-Windows2000/XP/Vista/7 operating system environment. And in this design also uses the Arduino application, which is a Windows-based compiler C language program for the Arduino microcontroller.

### 3.3 Circuit Block Diagram

A block diagram is a diagram in the form of a box (block) used to explain a work process in engineering science. For example, the work process of a certain tool, the work process of a certain circuit, the work process of a certain installation and so on.

### 3.4 System Block Diagram

The block diagram of the designed system is shown in Figure 3.1

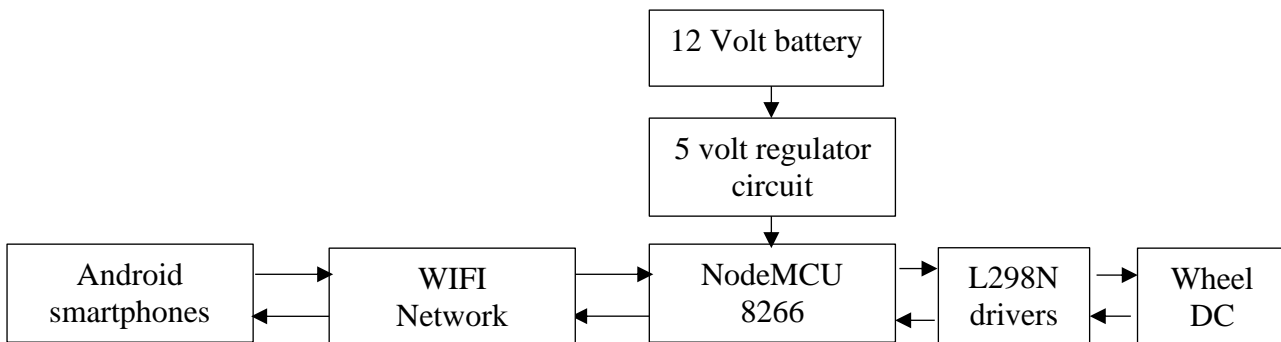

Figure 2: Circuit Block Diagram

### 3.5 Functions of Each Block

The function of each block in the designed tool system design is as follows:

1. 12 Volt battery serves as a power source.
2. The 5 Volt Regulator circuit functions to reduce the voltage from 12 volts to 5 volts.
3. Node MCU ESP8266 functions as a processor, receiver and sender of data.
4. Android functions as a remote control for controlling the movement of the car.
5. The WI-FI network functions as a communication medium between Android and the car's electronic system.
6. The L298N driver functions as a controller for the direction of rotation of the DC motor output.
7. Wheel DC Motor serves as the output driving the car.

### 3.6 The Node MCU ESP8266 suite

The Node MCU ESP8266 series functions as the control center for all existing systems. NodeMCU ESP8266 circuit drawing :



Figure 3: The NodeMCU ESP8266 circuit

Node MCU is basically a development of ESP 8266 with e-Lua based firmware. The Node Mcu is equipped with a micro USB port which functions for programming and power supply. Apart from that, Node MCU is also equipped with push buttons, namely reset and flash buttons. Node MCU uses the Lua programming language which is a package from esp8266. The Lua language has the same logic and programming structure as C, but the syntax is different. If you use the Lua language, you can use the Lua loader and Lua uploader tools. Apart from the Lua language, NodeMCU also supports the Arduino IDE software by making a few changes to the board manager on the Arduino IDE. Before use, this board must be flashed first so that it supports the tools to be used. If using the Arduino IDE, use the appropriate firmware, namely the output firmware from AiThinker that supports AT Command. To use the firmware loader tool that is used is the NodeMCU firmware.

**3.7 Voltage Stabilizer Circuit (Regulator)**

This circuit serves to provide supply voltage from the battery throughout the existing circuit. The output of this regulator circuit is 5 volts.

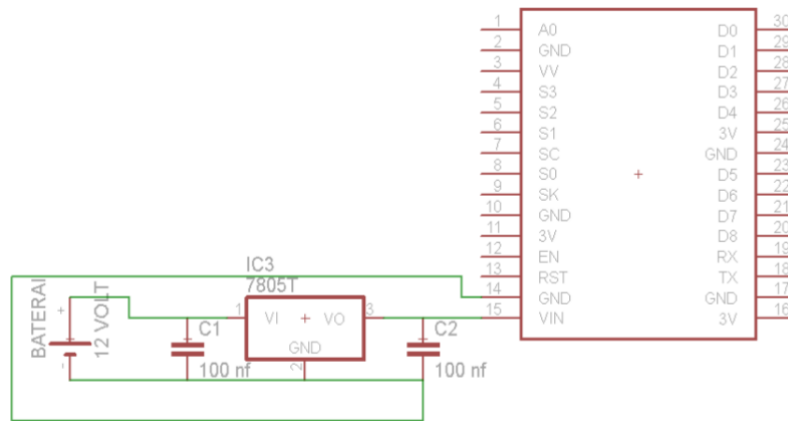

Figure 4: Regulator circuit

In the circuit above a 12 volt battery is connected to a 100 nf capacitor, then connected to the input voltage regulator IC 7805 to get a 5 volt dc output, this 5 volt dc output will serve to supply the Node MCU ESP8266 system.

**3.8 L298 1 Driver Circuit and Wheel DC Motor**

This circuit functions as a regulator of the direction of rotation or direction of movement of the DC Motor on the robot wheel:

**3.9 Overall sequence Tool System**

On the network This The 7805 regulator circuit functions to provide a voltage supply from the battery throughout the existing circuit. The output of this regulator circuit is 5 volts. Node MCU 8266 functions as a processor, data receiver, and WI-FI signal transmitter on the tool system, and then the heart rate sensor reads the heart rate value which is then displayed on the smartphone display.

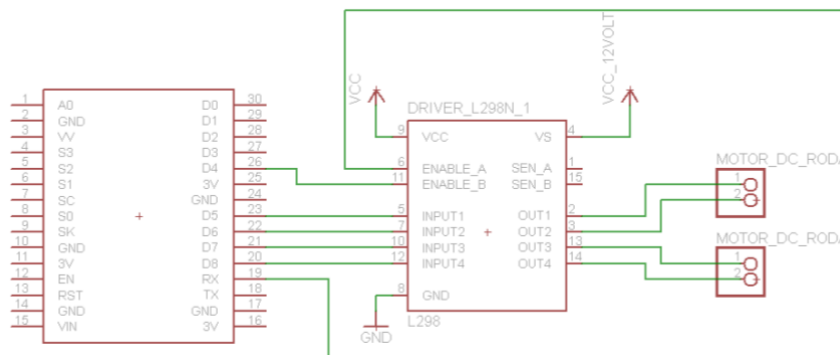

Figure 5: L298 Driver Circuit and Wheel DC Motor

In this study the researcher will explain about the flowchart so that the researcher can represent the steps that must be carried out in the design.

**4. Car Series.**

In this car circuit, the 7805 regulator circuit functions to supply voltage from the battery throughout the existing circuit. The output of this regulator circuit is 5 volts. NodeMCU 8266 functions as a processor, data receiver, and WI-FI signal transmitter for the car system, Driver L298N 1 functions as a controller for the direction of rotation of the DC motor wheel output, DC Motor functions as the output for driving the car wheels.

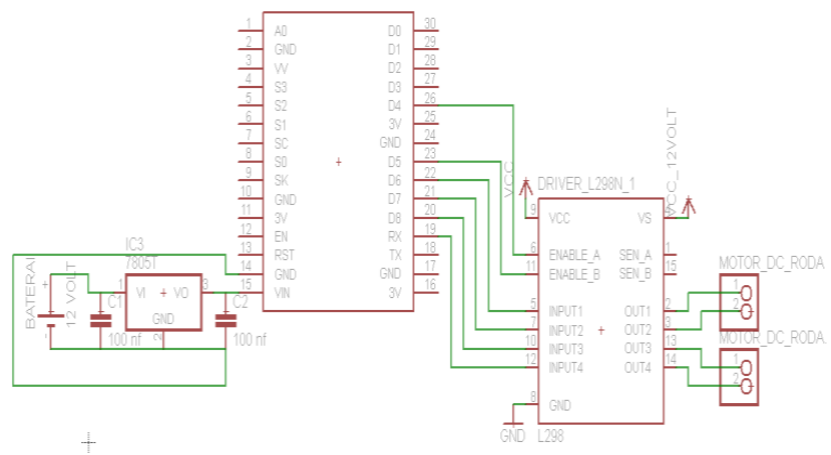

Figure 6: Overall series of Robot Systems

### 4.1 Flowchart System

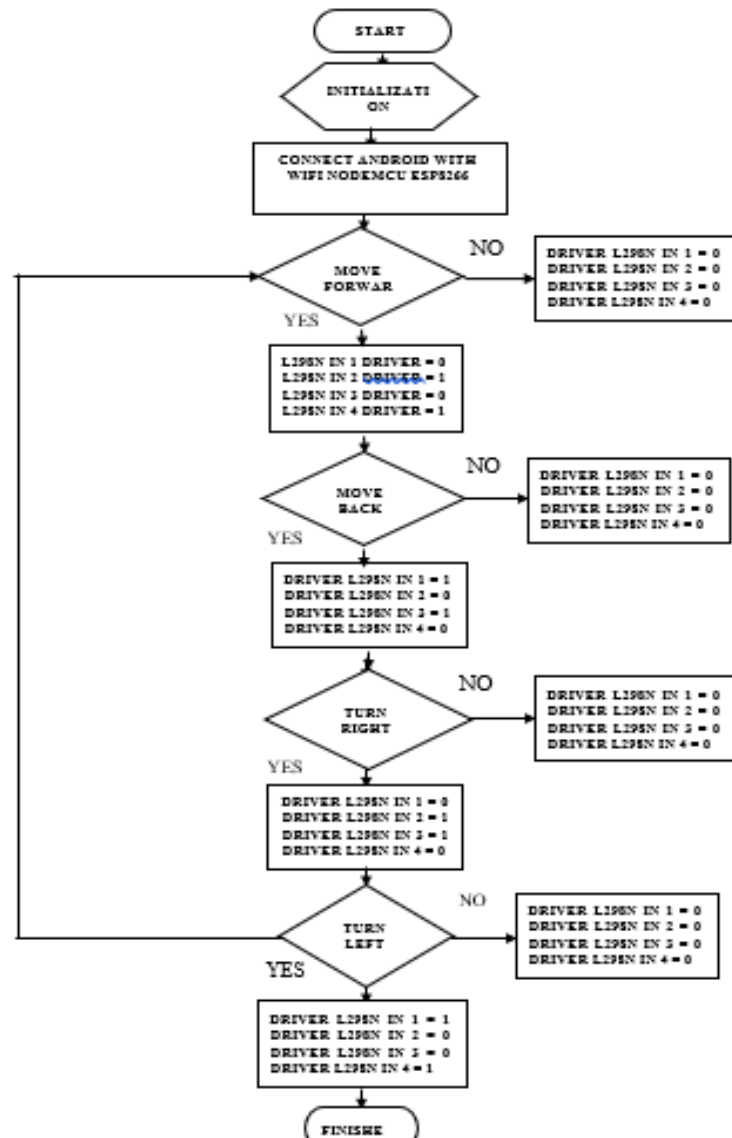

Figure 7: Flowchart System

## Reference

- [1] Edward, Setiawan. 1994. *Programming with C/C++ and Numerical Applications*. Erlangga. Jakarta.
- [2] Janner Simarmata. 2006. *Introduction to Computer and Information Technology*. Andi Yogyakarta. Yogyakarta.
- [3] Jogiyanto Hartono. 1993. *Basic Concepts of Language Programming C*. Andi Yogyakarta. Yogyakarta.
- [4] P. Insap Santosa. 1991. *Digital Engineering*. Andy Yogyakarta. Yogyakarta.
- [5] R. Harso Adjie. 2013. *Designing a USB I/O Board Using the PIC 18F4550 Chip*. Science House. Yogyakarta.
- [6] Rusman Hakim. 1998. *Learning to Know Yourself Computer Systems*. Gramedia. Jakarta.
- [7] Saludin Muis. 2013. *Perancangan Teori & Praktis Power Supply Jenis Switch Mode*. Graha Ilmu. Yogyakarta.