



## Design and Development of Swimming Pool Water pH Level Monitoring System and Automatic Solenoid Valve Control Based on the Internet of Things

Fahriza Rizky Maulana<sup>1\*</sup>, Yusfrizal<sup>2</sup>, Milli Alhfi Syari<sup>3</sup>

<sup>1,2,3</sup>Informatics Engineering, Universitas Potensi Utama

Jl. Veterans No. 4A-9A, Binjai, North Sumatra, Indonesia

[fahrizamaulana24@gmail.com](mailto:fahrizamaulana24@gmail.com)<sup>1</sup>, [yusfrizal80@gmail.com](mailto:yusfrizal80@gmail.com)<sup>2</sup>, [milli.fhiya@gmail.com](mailto:milli.fhiya@gmail.com)<sup>3</sup>

---

### Abstract

A device for monitoring the pH level of swimming pool water and an IoT-based automatic solenoid valve control has been specially designed. This system consists of several main components, including a pH sensor that continuously monitors the pH level in swimming pool water. This sensor will be connected to the Esp32 Board microcontroller which has been programmed to retrieve pH data periodically. The collected data will be sent via an internet connection to the cloud platform and can then be accessed via a mobile application to display real-time pH level messages. In addition, this system is also equipped with automatic solenoid valve control. Based on the measured pH data, the system will be able to make a decision to open or close the solenoid valve. If the pH level is outside the set limit, the system will automatically activate the solenoid valve to open the floodgates for filling water into the swimming pool, thus maintaining the pH balance automatically. In the design system for monitoring the pH level of swimming pool water and controlling this automatic solenoid valve using a pH-014 sensor which functions to detect the pH level in swimming pool water.

*Keywords:* Esp32 Board, Water, pH, Pool, Valve

---

### 1. Introduction

pH (hydrogen potential) is a measure of the acidity or base content of a swimming pool. PH can affect the health and well-being of pool users, as well as the cleanliness and clarity of pool water. If the pH of the pool water is too low (below 7), the pool water is too acidic. This can cause irritation to the eyes, nose and throat of the user, as well as corrosion to the pool, air passages, filtration system and can damage pool equipment such as pumps, filters and chemical treatment equipment. Conversely, if the pool's pH value is too high (above 8), the pond is too alkaline. This can cause skin, hair, and eye irritation and make the pool look cloudy and muddy. Water that is too alkaline can also reduce the effectiveness of chemical products such as chlorine which can reduce the ability to kill bacteria and keep pool water clean. Chlorine levels in swimming pools are useful for killing pathogenic microorganisms if there are excessive amounts in the water it can cause health problems and a water pH that is too high or too low produces an optimal chlorine effect and can cause calcareous deposits.

The research was conducted by Kursani E, student of Yulianto B at the Hang Tuah High School of Health Sciences Pekanbaru in 2019 with the research title "Analysis of Residual Chlorine and Phair Levels in Public Swimming Pools in Pekanbaru City". In this study, the pH of water is divided into 2, namely some are acidic and some are alkaline. Water is said to be acidic if the pH is less than 7, while alkaline is more than 7 and 7 can be said to be neutral [1].

### 2. Previous Research

#### 2.1. Monitoring

Monitoring is a cycle of activities that includes the process of collecting, reviewing reports and acting on information about a process that is being implemented. The surveillance system collects information about yourself and analyzes this information for your purposes. Maximize all available resources. The data collected is usually real-time data [2].

#### 2.2. Theory of pH levels

The level of pH or degree of acidity is used to express the level of acidity or base possessed by a substance, solution or object. pH levels in the morning 7.2 during the day 7.6 in the evening 7.2 water temperature in the morning 30.8°C during the day 31.1°C in the afternoon 31.4°C longer swimmers > 1 hour 72% use more swimming goggles who do not use 69% and complaints of greater eye irritation who do not experience complaints of eye irritation 81% [3].

### 2.3. Swimming Pool Water

Swimming pool water is water in a place in the form of a pool which is used for sports with the condition that its quality must meet health requirements. Swimming pool water quality must be fully maintained regularly and continuously, so that the water will be free from contamination/pollution. Swimming pool water is one of the water sources that can be a place for transmission of disease transmission between people [4].

### 2.4. Solenoid Valve

Solenoid valves are valves that are controlled by electrical energy via solenoids and have a coil as an actuator that uses AC or DC power to move the controlled piston. Solenoid valves have an inlet and an outlet. The function of the solenoid valve is to close, discharge, measure, distribute or mix fluids [5].

### 2.5. Microcontroller

Microcontroller is a digital electronic device that has input and output as well as control with a program that can be written and deleted in a special way, how the microcontroller actually reads and writes data. Programming on the microcontroller works by changing the value read on the sensor [6].

### 2.6. Esp32 Board

ESP32 is one of the microcontroller families introduced and developed by Espressif Systems. ESP32 is the successor of the ESP8266 microcontroller. This microcontroller is compatible with Arduino IDE. ESP32 has been integrated with an independent WiFi network as an ESP32 bridge with WiFi and added BLE (Bluetooth Low Energy) on the chip so that it is very supportive and can be a good choice for creating Internet of Things application systems [7].

### 2.7. Internet Of Things

Internet of Thing consists of 2 keywords, Internet and Things. Internet, has the meaning of interconnection-networking, where computer networks are connected to one another using the TCP/IP protocol. The way the internet of things works is that every object that has an internet of things sensor or module installed sends data or information to users via the internet and can be accessed anytime and anywhere without being limited by distance. The function of the internet of things itself is to facilitate monitoring and controlling of objects in everyday life. In addition, the information obtained can be obtained at any time on the internet of things [8].

## 2. Research methodology

### 3.1. Research Materials and Equipment

The implementation method in this study is generally divided into 5 stages as shown in the following diagram:



Fig. 1: Research Workflow

The materials used for Monitoring Pool Water PH Levels and Controlling Automatic Solenoid Valves Based on the Internet of Things are as follows:

1. The hardware used in this study is as follows:
  - a) ESP32 Board
  - b) pH-014 sensor
  - c) Solenoid valves NC 3/4
  - d) Relays 2 channels 5v
  - e) Mini water pump
  - f) Water hose
  - g) Breadboards
  - h) Acrylic
  - i) Jumper Cables
  - j) Smartphones
  - k) Some Glue and insulation
  - l) Solder and Solder Tin
2. The software used in this study is as follows:
  - a) Arduino IDE
  - b) Fritzing
  - c) Microsoft Word

### 3.2. Circuit block diagram

Hardware planning is designing electronic components in such a way that they have the desired function. In general, the tool design planning can be seen in Figure 2 as follows.

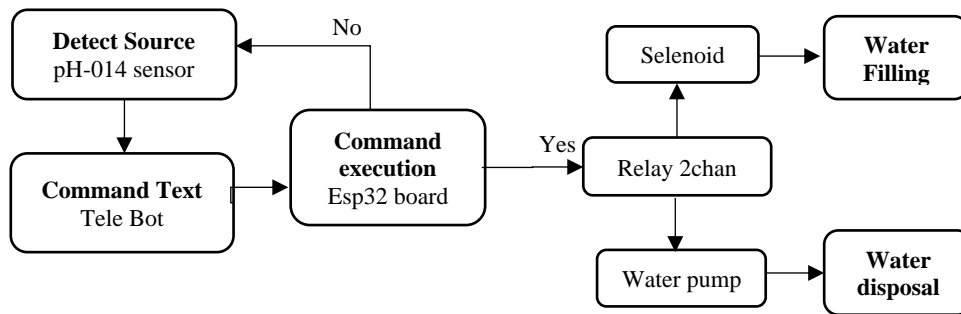

Fig. 2: System Block Diagram on the Esp32 Board

The description of the Flowchart above is as follows:

1. The Esp32 Board functions as the brain and controller function in the electronic system.
2. The pH-014 sensor sends a message via the Esp32 Board to the tele bot, the pH-014 sensor functions to measure the acidity level in swimming pool water.
3. Then the tele bot receives a message, if the pH level is normal there are no more commands, if the pH level is high or low it will send an active command to the relay
4. The 2Chan 5v relay functions as a switch for the Solenoid valve and the water pump.
5. The Solenoid valve NC 3/4 serves to fill clean water into the swimming pool and the water pump functions as a disposal for water with an abnormal pH.
6. After that the water will be removed and refilled, if the water pH level is normal it will stop automatically.

### 3.3. The Whole Range of Tools

This circuit is composed of the components needed to design the tool so that the data tool works as desired, which can be seen in Figure 3 below.

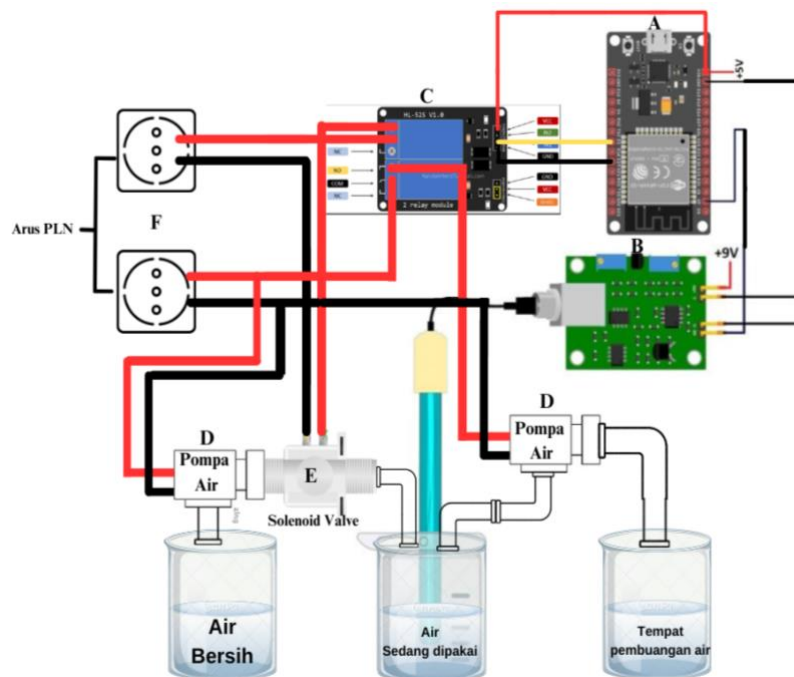

Fig. 3: The Whole Range of Tools

The explanation of Figure 3 is as follows:

- a. ESP32 is one of the microcontroller families introduced and developed by Espressif Systems. ESP32 is the successor of the ESP8266 microcontroller. The pins on the Esp32 Board have 39 input and output pins.
- b. The pH-014 sensor is a sensor that is a module that functions to detect the pH level of water, where the output is in the form of an analog voltage. The range of PH values is between numbers between 0 and 14 with the provisions as in table III.2 below.
- c. Relay 2Ch is a device that acts as a switch that works according to the electromagnetic principle. The relay will work if it is energized and disconnected if there is no electricity. The relay has output NO (Normally Open), COM (Common), NC (Normally Close)
- d. Water pumps are used to distribute water as well as fill and dispose of water in swimming pools where the pH level of the water is abnormal. In this design, a mini water pump is used which only has a small power.
- e. Solenoid valves are actuators that use AC or DC power to drive a controlled piston. Solenoid valves have an inlet and an outlet. Serves as a water filling in the swimming pool.
- f. Electric current is used to flow power current to each device.

#### 4. Flowchart System

Software planning starts from making flowcharts (flow diagrams) to facilitate planning and programming on the microcontroller. Making a flowchart (flow chart) also aims to make it easier to understand the work process of this tool. The program flowchart of this Final Project includes the control system for the running of this tool can be seen in Figure 4.

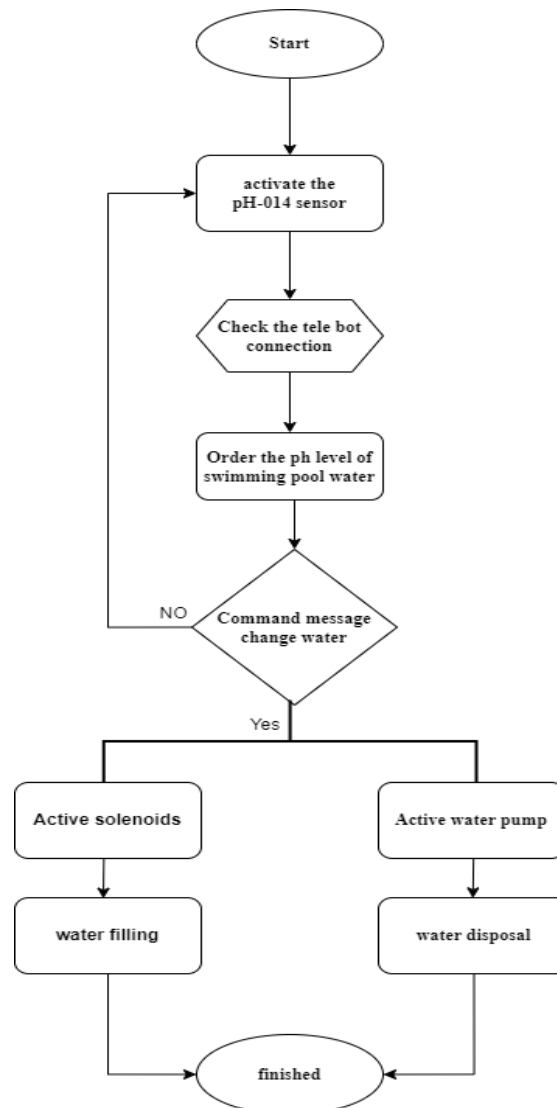

Fig. 4: Flowchart System

##### Information :

From the flowchart above, it can be explained that the design of this tool consists of several paths.

1. Start the program
2. Perform ON mode on the pH-014 sensor
3. Check the connection on the telegram bot
4. Checking the telegram bot messages sent from the pH-014 sensor
5. Order a water change order if a low or high pH level is detected
6. Filling the pool water
7. Disposing of pool water that is not normal
8. If not, will re-check in real-time

## 5. Implementastion and Testing

### 5.1 Hardware Set

After all the completed circuits have been designed in "Design of a swimming pool water pH monitoring system and automatic internet-based solenoid valve control", then all the completed circuits are combined. The following is a picture of the results of the system design shown in Figure 5.



Fig. 5: Hardware Set

### 5.2 Testing

For the results of testing the pH of the water under normal circumstances here I use clean water with a pH value of 6 to 8. The results of testing the pH of the water in an acidic condition I use lemon/orange water with a pH value below 6. The results of testing the pH of the water in an acidic condition I use soapy water with a pH value above 6.

## 6. Conclusion

After carrying out the design and manufacture stages of the system which is then followed by the testing and analysis stage, the following conclusions can be drawn:

1. The working principle of WI-FI on the device system is as a communication medium between the device system and the Android cellphone.
2. An Android phone can be used as a monitoring tool for monitoring swimming pool water pH sensors using an application that can be downloaded on the internet.
3. The Esp32 Board functions as a controller, data receiver, and data processor as well as a WI-FI signal receiver that can be connected to Android.

## References

- [1] R. A. R. Kursani E, Yulianto B, "Analisis Kadar Sisa Klorin Dan Ph Air Di Kolam Renang Umum Kota Pekanbaru," *J. Kesehat. Al-Irsyad*, Vol. Xii, No. 2, Pp. 11–22, 2019.
- [2] A. Gracetantiono And B. Wasito, "Implementasi Widgets Builder Untuk Monitoring Kinerja Sistem Komputer Dengan Menggunakan Rainmeter," *J. Inform. Dan Bisnis*, Pp. 1–10, 2021.
- [3] I. R. W. Mochamad Nibras Bimo Adhyaksa, Nur Asiah, "Gambaran Kualitas Kadar Chlorine, Suhu, Dan Ph Terhadap Faktor Lama Berenang Serta Penggunaan Kacamata Renang Pada Keluhan Iritasi Mata Perenang," *J. Kesehat. Lingkung. J. Dan Apl. Tek. Kesehat. Lingkung.*, Vol. 18, No. 1, Pp. 65–70, 2021, Doi: 10.31964/Jkl.V18i1.291.
- [4] F. B. Kurniawan *Et Al.*, "Kadar Klor Terhadap Kualitas Bakteriologi Pada Air Kolam," *Gema Kesehat.*, Vol. 14, No. 1, Pp. 101–107, 2022.
- [5] M. A. Handoyo, "Cara Kerja Dan Perawatan Inretlock System Safety Device Pada Mesin Induk Di Kn. Gandiwa P.118 Badan Pengusahaan Batam," *Gastron. Ecuatoriana Y Tur. Local.*, Vol. 1, No. 69, Pp. 5–24, 2020.
- [6] S. Asri And R. Siregar, *Sistem Kendali Kadar Ph Air Kolam Renang Outdoor Berbasis Mikrokontroler Atmega 32*. 2019.
- [7] D. Hardiansya Putra Makrup, Amalia Herlina, And Fuad Hasan, "Rancang Bangun Ruang Penyimpanan Bibit Bawang Merah Siap Tanam Menggunakan Board Esp32 Berbasis Internet Of Things," *Tesla J. Tek. Elektro*, Vol. 24, No. 2, Pp. 162–173, 2022, Doi: 10.24912/Tesla.V24i2.20270.
- [8] Y. A. S. Dendy Ramdani , Fahrudin Mukti Wibowo, "Rancang Bangun Sistem Otomatisasi Suhu Dan Monitoring Ph Air Aquascape Berbasis Iot (Internet Of Thing) Menggunakan Nodemcu Esp8266 Pada Aplikasi Telegram," *J. Informatics, Inf. Syst. Softw. Eng. Appl.*, Vol. 3, No. 1, Pp. 59–68, 2020, Doi: 10.20895/Inista.V2i2.