

Implementation of Gauss Elimination Method on Electrical Circuits Using Python

Ichwanul Muslim Karo Karo^{1*}, Justaman Arifin Karo Karo², Yuniarto³, Hariyanto⁴, Miftahul Falah⁵, Manan Ginting⁶

¹Ilmu Komputer, Universitas Negeri Medan
^{2,3,4,5,6} Politeknik Teknologi Kimia Industri
ichwanul@unimed.ac.id^{1*}

Abstract

Problem solving in engineering, science and other disciplines often requires complex and in-depth analysis. A problem that requires effort is determining the value of electric current in a circuit. Generally, the determination of the current value in a circuit with the calculation of Kirchoff's theorem. This research presents an alternative approach to determine the value of electric current in a circuit by combining the Gauss Elimination method and Kirchoff's theorem. The determining process support by Python. This method is effective in finding unknown values in a system of linear equations through matrix operations. A deep understanding of currents in electrical circuits is essential in the design, analysis, and maintenance of electrical systems. The application of the Gauss Elimination method becomes important in determining the value of current in complicated electrical circuits. In conclusion, this research simulates the electrical circuit of a boarding house. The Gauss Elimination Method is able to solve the electrical circuit problem by determining the electric current value of the circuit. Furthermore, this research also presents the results of identifying the voltage value of the circuit accurately and relevantly.

Keywords: Gauss Elimination, Electric Circuits, Systems of Linear Equations

1. Introduction

There are many problems in various areas of knowledge that require the application of mathematical models. One of them is the ability to solve problems related to electrical circuit analysis [1]. When solving problems on electrical circuits, it is important to remember that the circuit often consists of many components, including resistors, capacitors, and inductors, which are connected to each other through nodes. Determining the current in each component is very important as it plays a major role in determining the overall performance of an electrical circuit, such as voltage, power, and efficiency levels [2]. The importance of understanding current in an electrical circuit is undeniable in the context of designing, analyzing, and repairing electrical systems.

There are several techniques that can be used to analyze electrical circuits [3], that is node analysis and supernode analysis. Nodes refer to the point where two or more components in an electrical circuit intersect[4]. Both analyses are generally organized in the form of a mathematical model which is then described numerically through a System of Linear Equations (SPL). These mathematical models can be very complicated or contain more than two equations. Therefore, another approach is needed to solve the SPL.

The gauss elimination method is applied to find a solution a system of linear equations [5]. Let us review the definitions of these systems of equations. In mathematics, the Gaussian elimination approach is referred to as the row reduction algorithm for solving linear equation systems. It consists of a series of operations performed on the relevant matrix of coefficients. This method is common and powerful to be used for various cases that can be expressed in SPL[6], [7]. Several real problems were successfully solved with the Gauss elimination method, such as the problem of determining the position of a lost pedestrian [8], solving nuclear fuel depletion system. Furthermore, several tools or programming languages have also been used as support systems, such as, Matlab [9], Scilab [10] or C++ [11].

This research aims to present an alternative way to determine the value of electric current in an electrical circuit using the Gauss Elimination method approach and support by Python. In addition, this research presents the process of solving transformed electrical circuit problems in matrix form. In such a way that it can be applied efficiently to get the right and relevant solution in the context of electrical problems.

2. Research Method

This study contains five processes (shown in Figure 1). These are initializing the research, Deriving Equation by Kirchoff's Law, transform equation to matrix, solved by Gauss elimination method and analyzing the results.

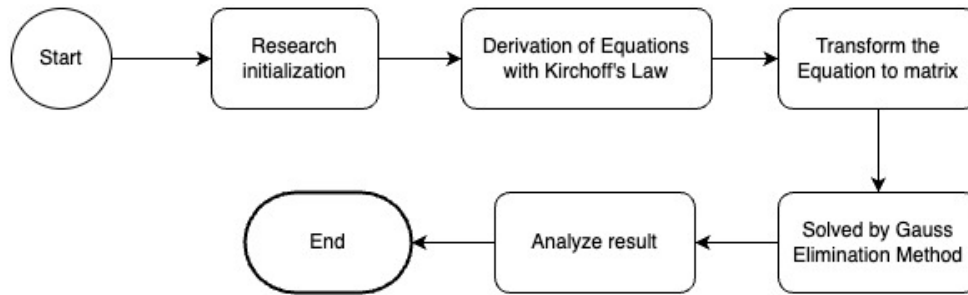

Fig. 1: Research workflow

2.1. Research initialization

At this stage, researchers define research objectives, study literature to find simple electrical circuits to be used as simulation material. In addition, researchers determine the parameters to be studied, such as current and voltage on each component.

2.2. Kirchhoff's law

Kirchhoff's theory was first introduced by Gustav Robert Kirchhoff [4]. Kirchhoff's first law declares "The amount of electric current entering (ΣI_{in}) a node in a circuit must be equal to the amount of electric current leaving (ΣI_{out}) the node". Mathematically, this can be formulated by the Equation (1). Kirchhoff's second law relates to Kirchhoff's Voltage Law or Loop. The law states, "The sum of the voltage (R) drops in a loop in the circuit must be equal to the sum of the voltage increases". This can be formulated by the equation (2).

$$\Sigma I_{in} = \Sigma I_{out} \quad (1)$$

$$\Sigma \varepsilon + \Sigma IR = 0 \quad (1)$$

2.3. Gauss elimination method

This study uses Gauss elimination method to perform the three types of matrix row operations on an augmented matrix obtained from a linear system of equations to find the solutions for such a system is known as the Gaussian elimination method. Row (R) reduction is a technique that consists of two stages: forward elimination and back substitution. The difference between these two Gaussian elimination method phases is the output they create, not the activities you can perform through them. The row reduction required to simplify the matrix in question into its echelon form is referred to as the forward elimination step. A goal of this stage is to demonstrate if the system of equations represented in the matrix has a single feasible solution, an unlimited number of solutions, or no solution at all. If it is discovered that the system has no solution, there is no need to proceed to the next stage of row reduction.

The Gaussian elimination with the back substitution step is carried out if solutions for the variables involved in the linear system can be found. This final step yields a reduced echelon form of the matrix, which yields the system of linear equations' general solution. The Gaussian elimination rules are the same as the rules for the three basic row operations, in other words, you can algebraically act on a matrix's rows in the following three ways:

1. Interchanging two rows, for example, $R2 \leftrightarrow R3$
2. Multiplying a row by a constant, for example, $R1 \rightarrow kR1$ where k is some nonzero number
3. Adding a row to another row, for example, $R2 \rightarrow R2 + 3R1$

3. Results and discussion

This research successfully identified an electrical installation from a boarding room in Medan City. The electrical installation was redrawn into an electrical circuit (shown in Figure 2). The condition is an example of a real case to be simulated and determined the value of the voltage generated from each loop with the Gauss elimination method. There are four loops in the electrical circuit and four sources of electric current. (i_1, i_2, i_3, i_4). Each loop is identified with the first Kirchhoff's law approach so that all four loops become SPLs.

$$\text{Loop 1: } 9i_1 - 4i_2 - 2i_3 = 24$$

$$\text{Loop 2: } -4i_1 + 17i_2 - 6i_3 - 3i_4 = -16$$

$$\text{Loop 3: } -2i_1 - 6i_2 + 14i_3 - 6i_4 = 0$$

$$\text{Loop 4: } -3i_2 - 6i_3 + 11i_4 = 18$$

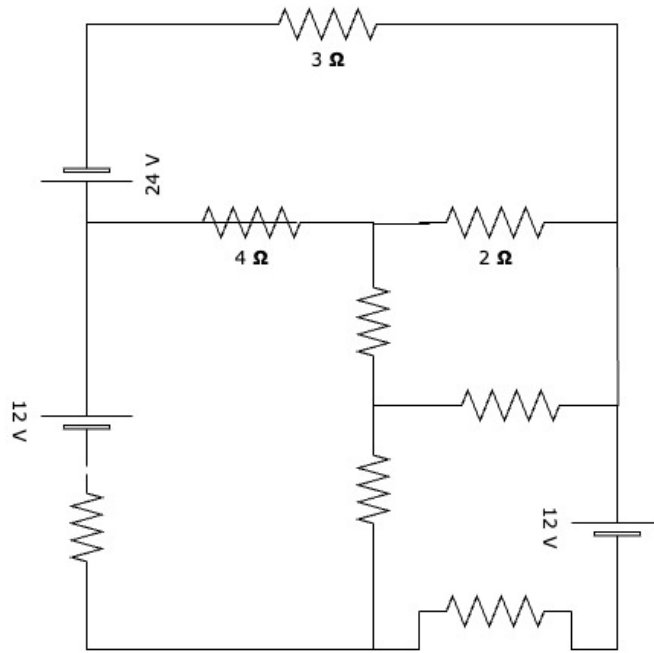

Fig. 2: Example of electrical circuit

3.1. Gauss elimination result

Furthermore, the SPL of the Loop (shown in previous subsection) is transformed into a 4x4 matrix, according to the number of electric current variables (i). Then the matrix equation is obtained as follows:

$$\begin{bmatrix} 9 & -4 & -2 & 0 \\ -4 & 17 & -6 & -3 \\ -2 & -6 & 14 & -6 \\ 0 & -3 & -6 & 11 \end{bmatrix} \begin{bmatrix} i_1 \\ i_2 \\ i_3 \\ i_4 \end{bmatrix} = \begin{bmatrix} 24 \\ -16 \\ 0 \\ 18 \end{bmatrix}$$

Conceptually, the Gauss elimination method is used to determine the value of each electric current. The way it works is to make the 4 x 4 matrix into an identity matrix. The solution steps are as follows:

First iteration: operated ($R_1/9$) in other words dividing row 1 by 9. So that the resulting equation

$$\begin{bmatrix} 9 & -4 & -2 & 0 \\ -4 & 17 & -6 & -3 \\ -2 & -6 & 14 & -6 \\ 0 & -3 & -6 & 11 \end{bmatrix} \begin{bmatrix} i_1 \\ i_2 \\ i_3 \\ i_4 \end{bmatrix} = \begin{bmatrix} 24 \\ -16 \\ 0 \\ 18 \end{bmatrix} \xrightarrow{R_1/9} \begin{bmatrix} 1 & -0,4 & -0,2 & 0 & 2,6 \\ -4 & 17 & -6 & -3 & -16 \\ -2 & -6 & 14 & -6 & 0 \\ 0 & -3 & -6 & 11 & 18 \end{bmatrix}$$

The second iteration operates on the first row such that all values of the first column (except diagonal 1) are 0. The second row is operated with $R_1 + R_2/4$ and the third row is operated with $R_1 + R_2/2$. Meanwhile, the fourth line is not operated because it is already 0.

$$\begin{bmatrix} 1 & -0,4 & -0,2 & 0 & 2,6 \\ -4 & 17 & -6 & -3 & -16 \\ -2 & -6 & 14 & -6 & 0 \\ 0 & -3 & -6 & 11 & 18 \end{bmatrix} \xrightarrow{\begin{matrix} R_1 + R_2/4 \\ R_1 + R_2/2 \end{matrix}} \begin{bmatrix} 1 & -0,4 & -0,2 & 0 & 2,6 \\ 0 & 15,2 & -6,8 & -3 & -5,3 \\ 0 & -6,8 & 13,5 & -6 & 5,2 \\ 0 & -3 & -6 & 11 & 18 \end{bmatrix}$$

The third iteration operates on the second row so as to obtain the identity matrix component. In other words, making the value of 15.2 into 1.

$$\begin{bmatrix} 1 & -0,4 & -0,2 & 0 & 2,6 \\ 0 & 15,2 & -6,8 & -3 & -5,3 \\ 0 & -6,8 & 13,5 & -6 & 5,2 \\ 0 & -3 & -6 & 11 & 18 \end{bmatrix} \xrightarrow{R_2/15,2} \begin{bmatrix} 1 & -0,4 & -0,2 & 0 & 2,6 \\ 0 & 1 & -0,4 & -0,19 & -0,35 \\ 0 & -6,8 & 13,5 & -6 & 5,2 \\ 0 & -3 & -6 & 11 & 18 \end{bmatrix}$$

Iteration will continue until the identity matrix is obtained. This research produces an identity matrix in the eighth iteration. With the final result as the matrix below. At the eighth iteration, the strong current value (i) in each loop is obtained. So obtained for the current value in each loop is $i_1 = 4,04$, $i_2 = 1,61$, $i_3 = 2,96$, $i_4 = 3,8$.

$$\begin{bmatrix} 1 & 0 & 0 & 0 & 4,04 \\ 0 & 1 & 0 & 0 & 1,61 \\ 0 & 0 & 1 & 0 & 2,96 \\ 0 & 0 & 0 & 1 & 3,8 \end{bmatrix}$$

In addition to the simulation process of the Gauss elimination method manually, this research has also run the Gauss elimination algorithm using the Python programming language. In order to simplify the computational process, the determination of the electric current value with the Gauss elimination method is also successfully implemented with Python. The electric current value produced by the two methods is not much different, only 3-6% only. So we can conclude that there is no significant difference between the two.

```

12 # Gaussian elimination method
13 for k in range(n-1):
14     for i in range(k+1, n):
15         factor = A[i, k]/A[k, k]
16         b[i] = b[i] - factor*b[k]
17         for j in range(k, n):
18             A[i, j] = A[i, j] - factor*A[k, j]
19 # Back substitution
20 x = np.zeros(n)
21 x[n-1] = b[n-1]/A[n-1, n-1]
22 for i in range(n-2, -1, -1):
23     sum = b[i]
24     for j in range(i+1, n):
25         sum = sum - A[i, j]*x[j]
26     x[i] = sum/A[i, i]
27
28 print(x)
29
[4.0402963  1.61066667  2.96  3.8 ]

```

Fig. 3: Gauss elimination using Python

3.2. Voltage analysis

The next stage analyzes the voltage value (V) in each loop. The V value is determined using Kirchhoff's second law ($V = \sum IR$). The purpose of analyzing voltage values in electrical circuits is troubleshooting and maintenance of electrical circuits in boarding houses and many more. The amount of voltage in the boarding house electrical circuit obtained is presented in the matrix below.

$$\begin{bmatrix} 9 & -4 & -2 & 0 \\ -4 & 17 & -6 & -3 \\ -2 & -6 & 14 & -6 \\ 0 & -3 & -6 & 11 \end{bmatrix} x = \begin{bmatrix} 4,04 \\ 1,61 \\ 2,96 \\ 3,8 \end{bmatrix}$$

4. Conclusion

Based on the results of electrical circuit identification, experiment simulation and analysis, the Gauss elimination method can be applied to determine the value of electric current in electrical circuits. To simplify the computation process, the Gauss elimination process can be implemented using Python. In conclusion, this research successfully found a solution for the current and voltage values in the analyzed electrical circuit. The mathematical method used proved to be effective in solving the problem, and the results can be used as a basis for a better understanding of the characteristics and behavior of complex electrical circuits.

Acknowledgement

The authors would like to thank the Faculty of Mathematics and Natural Science, Big data and Artificial Intelligent Research Center Medan State University and Polytechnic of Industrial Chemical Technology for supporting this work.

References

- [1] S. Harahap, F. 'Analisis Dan Penyelesaian Model Matematika Pada Rangkaian Listrik Orde Dua', *Journal of Mathematics Education and Science*, vol. 6, no. 1, 2020.
- [2] Y. F. Setiaji, H. Hermawan, and M. Facta, 'ANALISIS DAN PENENTUAN KOORDINASI PROTEKSI RELE ARUS LEBIH SISTEM TEGANGAN MENENGAH DAN TEGANGAN RENDAH DI AREA PEMBEBANAN SENDIRI PLTP DARAJAT', *Transient: Jurnal Ilmiah Teknik Elektro*, vol. 10, no. 3, 2021, doi: 10.14710/transient.v10i3.442-449.
- [3] A. Nawaz, N. Sarwar, D. I. Jeong, and D. H. Yoon, 'Energy from discarded graphite-based pencils: Recycling the potential waste material for sensing application', *Sens Actuators A Phys*, vol. 336, 2022, doi: 10.1016/j.sna.2022.113403.
- [4] D. Anugrah, 'Penerapan Hukum Kirchhoff dan Hukum Ohm pada Analisis Rangkaian Listrik Menggunakan Software Electronics Workbench', *Journal of Systems, Information Technology, and Electronics Engineering*, vol. 2, no. 2, 2022.
- [5] G. B. Basnet, 'Numerical Solution of Electrostatic Potential Distribution on a Unit Circular Disc Using Poisson Equation', *Nepal Journal of Mathematical Sciences*, vol. 4, no. 1, 2023, doi: 10.3126/njmathsci.v4i1.53158.
- [6] N. Van Tran and I. van den Berg, 'A parameter method for linear algebra and optimization with uncertainties', *Optimization*, vol. 69, no. 1, 2020, doi: 10.1080/02331934.2019.1638387.

-
- [7] H. Egts, D. J. Durben, J. A. Dixon, and M. H. Zehfus, 'A Multicomponent UV analysis of α - And β -acids in hops', *J Chem Educ*, vol. 89, no. 1, 2012, doi: 10.1021/ed1010536.
- [8] N. A. Mufid, 'Implementasi Matriks Augmented dan Metode Eliminasi Gauss-Jordan untuk Menyelesaikan Masalah GPS (Studi Kasus: Menentukan Posisi Pejalan Kaki yang Tersesat)', *Jurnal Pendidikan Matematika*, vol. 1, no. 1, 2023, doi: 10.47134/ppm.v1i1.111.
- [9] S. Adnan and R. Anugrahwy, 'Implementasi Metode Eliminasi Gauss Pada Rangkaian Listrik Menggunakan Matlab', *JITEKH (Jurnal Ilmiah Teknologi Harapan)*, vol. 6, no. 01, 2017.
- [10] K. Anam, 'IMPLEMENTASI METODE NUMERIK PADA RANGKAIAN LISTRIK MENGGUNAKAN SCILAB', *Jurnal Penelitian*, vol. 5, no. 1, 2020, doi: 10.46491/jp.v5e1.487.59-67.
- [11] D. Henry, V. Hariadi, and R. Soelaiman, 'Desain dan Analisis Algoritma Pencarian Prediksi Hasil Penjumlahan Beberapa Urutan Berkala dengan Metode Eliminasi Gauss', *Jurnal Teknik ITS*, vol. 6, no. 2, 2018, doi: 10.12962/j23373539.v6i2.25568.