

Prototype Design IoT Based Air Quality Monitoring Tool for Urban Environment

Catlya Novera Lita^{1*}, A M H Pardede², Siswan Syahputra³

^{1, 2, 3}STMIK Kaputama

catlyanoveralita04@gmail.com^{1*}; akimmhp@live.com²; siswansyahputra90@gmail.com³

Abstract

In rapidly urban environments, air quality has become an important issue that affects public health and the environment. This research aims to design and implement a prototype of an IoT-based air quality monitoring device that can be used to monitor air conditions in urban environments. This prototype uses the DHT11 sensor for measuring temperature and humidity, the MQ135 sensor to detect the concentration of air pollutants such as CO, CO₂, ALCOHOL, TOLUENE, NH₄, and ACETONE, and an OLED LCD for displaying information. This system uses the NodeMCU ESP8266 as a microcontroller that connects devices to the internet and sends data to the Blynk application platform. The Blynk application serves as a user interface that allows for real-time monitoring of the device through a smartphone. With this system, users can obtain real-time air quality data to protect health and the environment in urban areas. The prototype evaluation shows that this system is effective in monitoring and displaying air quality information, as well as providing easy access to data through the Blynk application.

Keywords: MQ-135 Sensor, DHT11 Sensor, Blynk, IoT, LCD OLED

1. Introduction

The air quality in urban areas is currently deteriorating due to the increasing number of motor vehicles, industries, and other human activities, leading to issues such as air pollution, respiratory problems, and negative impacts on the environment. Air pollution is a common cause of pneumonia and can affect the respiratory system, overall health, and performance. This is caused by polluted air entering the lungs, leading to inflammation. This disease occurs more frequently in children because their immune systems are weaker compared to adults [1]. Since air is an essential part of life, the quality of air must be maintained and improved to provide the best respiratory capacity for living beings. Air pollution is currently on the rise, leading to negative impacts on human health due to the declining quality of air [2]. Based on the background description above, the author has decided to title this research " Prototype Design Of Internet Of Things (IoT)-Based Air Quality Monitoring Tool For Urban Environment."

2. Theoretical framework

2.1. DHT11 sensor

The DHT11 sensor is a very popular temperature and humidity sensor that is often used in Arduino-based projects and other microcontroller applications. By outputting a digital signal on the data pin, the DHT-11 is a highly stable and durable temperature and humidity sensor. No additional analog input signal is needed for it to function [3].

2.2. MQ-135 sensor

Unlike other MQ series gas sensors, the MQ-135 gas sensor can detect compounds and levels of hazardous gases that affect air quality and human respiration. The results of air quality detection are indicated by changes in the analog resistance value at the output pin. When the gas concentration in the air exceeds the threshold, the digital terminal goes HIGH and the analog output terminal goes LOW. When the gas concentration in the air exceeds the threshold, the digital pin is set to HIGH [4].

2.3. Internet of things

The Internet of Things, commonly known as IoT, is a system aimed at expanding the utilization of continuously connected internet connectivity. Capabilities such as data sharing, remote control, and so on also apply to real-world objects, for example, food products, electronics, equipment connected with sensors, and connected to networks [5].

2.4. Blynk

Blynk is an IoT (Internet of Things) platform that allows users to control hardware such as Arduino, Raspberry Pi, and similar devices through a mobile application. Blynk is designed for the Internet of Things (IoT) to quickly and easily control and read sensor data remotely from Arduino or ESP8266 devices [6], [7].

3. Analysis and design

3.1. Research Equipment and Materials

The materials used for the design of the IoT-based air quality monitoring prototype for urban areas are as follows [8], [9]:

1. The hardware used in this research includes:
 - 1) NodeMCU ESP8266
 - 2) MQ-135 Sensor
 - 3) DHT11 Sensor
 - 4) Board
 - 5) Jumper Cables
 - 6) WIFI Network
 - 7) Smartphone
 - 8) USB Cable
 - 9) Several Screws and Nuts
2. The software used in this research includes:
 - 1) Arduino IDE
 - 2) Blynk Application
 - 3) Fritzing

3.2. Block Diagram

The block diagram of the designed system is as shown in Figure 1

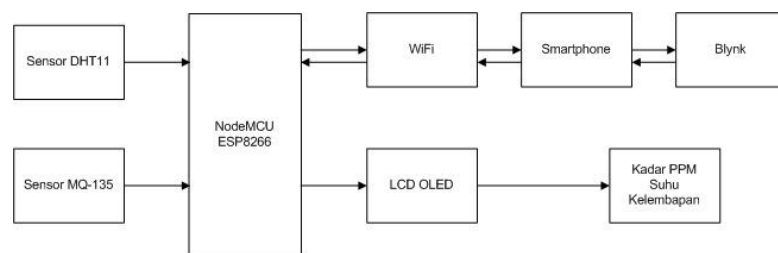

Fig. 1: Block diagram

3.3. System Tool Series

This circuit is composed of the components necessary to design a system so that the device can function as intended [10], [11].

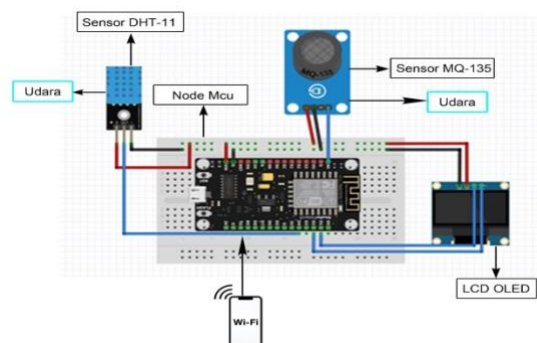

Fig. 2: System tool

3.4. System Flowchart

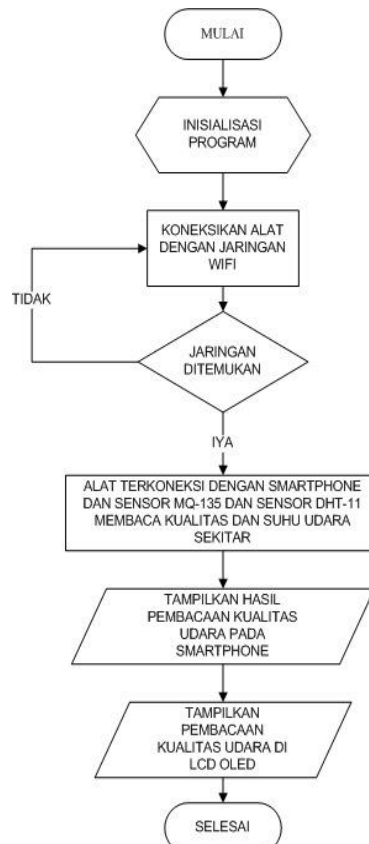

Fig. 3: System flowchart

4. Discussion and implementation

4.1. Hardware Testing

After all the circuits designed for the "Fish Drying Tool Prototype for Salted Fish Production Based on the Internet of Things" have been completed, the next step is to integrate all the finished circuits. The following is a description of the results from the system design, which can be seen in Figure 4.

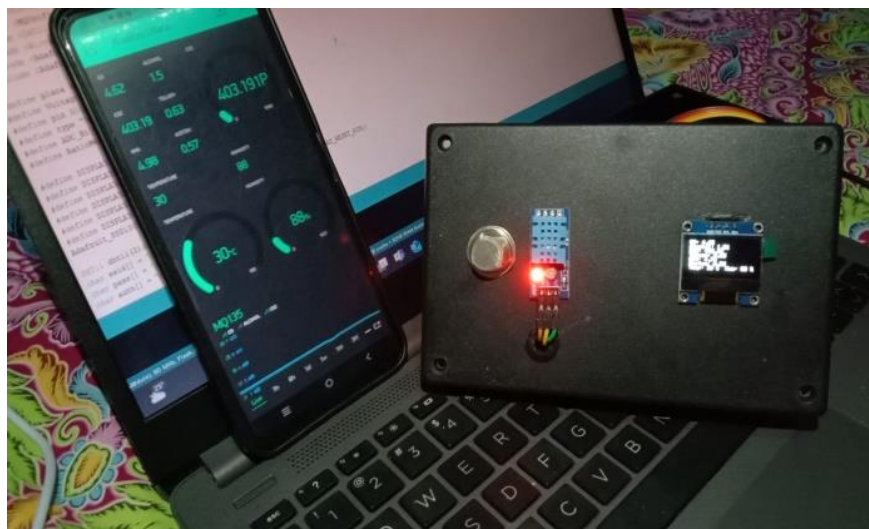

Fig. 4: Hardware testing

4.2. Blynk Output Results

The output result of the application is designed using the Blynk app, which can be downloaded from the Google Play Store. It can be seen in Figure 5.



Fig. 5: Blynk output display

5. Conclusion and suggestion

5.1. Conclusion

1. This thesis demonstrates that IoT-based air quality monitoring offers innovative solutions to air quality issues in urban environments. This technology utilizes the capabilities of sensors and internet connectivity to provide accurate and real-time data on air conditions.
2. The implementation of this monitoring tool allows for real-time air quality monitoring with greater efficiency compared to traditional methods. The collected data can be accessed directly and continuously, enhancing the response to changes in air quality.

5.2. Suggestion

1. Design the system to be easily integrated with existing IoT platforms and ensure that sensor calibration procedures are carried out regularly to maintain measurement accuracy.
2. Conduct trials in various urban locations to ensure the device operates well under different environmental conditions and perform regular evaluations for improvements and enhancements.

Acknowledgement

I would like to express my heartfelt thanks to my supervisor and friends who have helped me complete this thesis, allowing me to publish this journal.

References

- [1] Erik, M., Nurdiyanto, F., & Hidayat, R. (2024). AeroSense Monitor Integrasi Sensor DHT11 dan MQ135 untuk Pemantauan Kualitas Udara Berbasis Arduino Uno. *Jurnal Komputer Dan Elektro Sains*, 2(2), 8–11. <https://doi.org/10.58291/komets.v2i2.171>
- [2] Rizky, R. R., & Hakim, Z. (2020). Implementasi Metode Fuzzy Sugeno Untuk Sistem Pengukuran Kualitas Udara Di Kota Pandeglang Berbasis Internet Of Things (IOT). *Syntax : Jurnal Informatika*, 9(1), 15. <https://doi.org/10.35706/syji.v9i1.3439>
- [3] Siswanto, S., Anif, M., Hayati, D. N., & Yuhefizar, Y. (2019). Pengamanan Pintu Ruang Menggunakan Arduino Mega 2560, MQ-2, DHT-11 Berbasis Android. *Jurnal RESTI (Rekayasa Sistem Dan Teknologi Informasi)*, 3(1), 66–72. <https://doi.org/10.29207/resti.v3i1.797>
- [4] Rombang, I. A., Setyawan, L. B., & Dewantoro, G. (2022). Perancangan Prototipe Alat Deteksi Asap Rokok dengan Sistem Purifier Menggunakan Sensor MQ-135 dan MQ-2. *Techné : Jurnal Ilmiah Elektroteknika*, 21(1), 131–144. <https://doi.org/10.31358/techné.v21i1.312>
- [5] Susanto, F., Prasiani, N. K., & Darmawan, P. (2022). Implementasi Internet of Things Dalam Kehidupan Sehari-Hari. *Jurnal Imagine*, 2(1), 35–40. <https://doi.org/10.35886/imagine.v2i1.329>
- [6] Nasution, A. H. M., Indriani, S., Fadhilah, N., Arifin, C., & Tamba, S. P. (2019). Pengontrolan Lampu Jarak Jauh Dengan Nodemcu Menggunakan Blynk. *Jurnal TEKINKOM*, 2, 93–98.

-
- [7] F. Fadillah, R. Buatun, and S. Ramadani, "IoT-based Hydroponic Plant Monitoring System", *j. of artif. intell. and eng. appl.*, vol. 3, no. 1, pp. 38–43, Oct. 2023.
 - [8] R. Sinaga, N. Novriyenni, and S. Syahputra, "Design of an Automatic Water Faucet System Using the IOT Based HC-SR04 Sensor", *j. of artif. intell. and eng. appl.*, vol. 3, no. 1, pp. 274–278, Oct. 2023.
 - [9] Rizky Hidayat, N. Novriyenni, and Siswan Syahputra, "Design of a Temperature Control and Object Motion Detection System in the Server Room Using IOT-Based Wemos D1", *j. of artif. intell. and eng. appl.*, vol. 3, no. 1, pp. 323–327, Oct. 2023.
 - [10] Muhammad Alfanny, Achmad Fauzi, and Hermansyah Sembiring, "Design and Build a System for Turning on an IoT-Based Motorcycle Starter Using Voice", *j. of artif. intell. and eng. appl.*, vol. 3, no. 1, pp. 357–362, Oct. 2023.
 - [11] Rizki juli syahputra, "Monitoring The Temperature And Humidity Air In The Room Using A Sensor IOT-Based DHT-11", *j. of artif. intell. and eng. appl.*, vol. 3, no. 1, pp. 363–367, Oct. 2023.