



## Design and Construction of Guest Friendly Robot for Front Office Service on Campus Based on IoT

Dea Nanda Putri Purwani<sup>1\*</sup>, Relita Buaton<sup>2</sup>, Milli Alfhi Syari<sup>3</sup>

<sup>1, 2, 3</sup>STMIK Kaputama

[deaa6391@gmail.com](mailto:deaa6391@gmail.com)<sup>1\*</sup>, [bbcbuatan@gmail.com](mailto:bbcbuatan@gmail.com)<sup>2</sup>, [milli.fhisya@gmail.com](mailto:milli.fhisya@gmail.com)<sup>3</sup>

---

### Abstract

Amid the rapid advancements of the digital era, Internet of Things (IoT) technology has emerged as one of the most significant innovations, enabling electronic devices to connect and interact intelligently. This study aims to design and develop an IoT-based guest reception robot intended for front office services at the campus. The robot is designed as a prototype capable of welcoming guests, saying "welcome," and providing four key pieces of information about the campus. Utilizing components such as ESP32 and ultrasonic sensors, the robot is expected to enhance service efficiency while also offering a more interactive experience for campus visitors. The implementation of IoT in this robot is not only intended to improve visitor services but also to promote technological innovation within the campus environment. This study also explores the integration of hardware and software, as well as the features and functions needed to meet the requirements of front office services. Thus, this research is expected to serve as a foundational step toward creating a more modern and innovative campus.

**Keywords:** Ultrasonic Sensor, ESP32, Internet of Things, Robotic

---

### 1. Introduction

Along with the transition from the previous digital era to an increasingly digital era, the role of technology is increasing in various aspects of human life. The Internet of Things (IoT) has changed human interaction with the environment, and it is the most well-known innovation in recent years. By enabling various electronic devices to connect to the internet and each other, the Internet of Things opens up new opportunities in various fields, including customer service. Now, robotics components can enter the fields of entertainment, education, and health. Making robots with special advantages and skills is closely related to the needs in the modern industrial world which demands the existence of a tool with high capabilities that is useful for assisting human work or on the other hand this sophisticated technology is useful for completing work that humans are unable and unwilling to do.[1]

On a campus, front office services not only serve as a point of contact for questions and assistance, but also as a representation of the institution's identity and image. Therefore, improving the guest experience is of paramount importance. By implementing IoT technology, campuses can provide a more personalized and interactive guest experience. Apart from that, implementing IoT can also open up new opportunities in data collection and analysis. Data generated by various sensors can be used to analyze user habits, predict service demand trends, and identify areas where efficiency can be improved. Thus, IoT not only enhances the guest experience, but also provides valuable insights for strategic decision making at the campus management level.[2]

### 2. Literature Review

#### 2.1. Design

This design is a robot that welcomes guests and provides information about the campus. The design includes a box-shaped body, with two arms, two legs, and a boxy head. The main components used include ultrasonic sensors to detect guests, servo motors for arm movement, LCD screen to display information, keypad for selecting information, DFPlayer Mini for sound playback, and ESP32 as the main controller. This robot is also connected to Firebase for storing input data from the keypad and has a WiFi connectivity feature.

#### 2.2. Esp32

ESP32 is an advanced microcontroller developed by Espressif Systems, a company based in Shanghai, China. This microcontroller is designed to provide an integrated WiFi networking solution, allowing devices to function independently within a WiFi network or act as a

connector between other microcontrollers and a WiFi network. The ESP32 is equipped with a dual-core processor using the Xtensa LX6 architecture, providing powerful and efficient performance for a wide range of IoT applications, from home automation to smart devices. With features like Bluetooth, abundant GPIOs, and support for a variety of communications protocols, the ESP32 is a popular choice for developers who need flexibility and computing power in one compact package.[3]

### **2.3. Robot**

The word "robot" comes from the term "robota," which means worker. Robots can be defined as mechanical devices that are capable of operating continuously to assist human tasks. This robot can be controlled directly by humans or work automatically according to a program programmed into the controller chip.[4]

The word "robot" has become a term we commonly hear. When we hear about robots, our minds often focus on objects that resemble humans and can move and talk automatically with control from a microcontroller. The term robot comes from the Czech word "robota," which means "worker." The term was first introduced into English in 1921 by writer Karel Čapek in the play "Rossum's Universal Robots" (RUR). Robots are machines assembled by humans, but capable of operating without getting tired.[5]

### **2.4. Humanoid Robots**

Humanoid robots are a type of robot designed to have a shape, structure or movement that resembles humans. These robots usually have a head, body, hands and feet, and can imitate human movements, such as walking, talking or social interaction. The main goal of developing humanoid robots is to create machines that can interact with humans in a more natural and intuitive way. Humanoid robots are often used in various fields, such as education, research, entertainment, and service, as well as in situations where human-robot interaction is required.[6]

### **2.5. Robotics Technology**

The development of robots is closely related to the needs of modern industry, which requires tools with high capabilities to help complete tasks that cannot be done by humans or that require higher efficiency.

With advances in technology, robots are now designed to carry out a variety of functions, from complex production processes to tedious routine tasks. In the manufacturing industry, for example, robots are used to assemble components, perform welding, and package goods, thereby increasing productivity and reducing errors. In addition, the use of robots also helps reduce the risk of injury for human workers, especially in jobs that are dangerous or require high precision.

Furthermore, the development of robotics is not only limited to industry. Robots are now also used in healthcare to perform surgical procedures with high precision, in agriculture to increase crop yields, and even in everyday life as personal assistants at home. As such, innovation in robotic technology is increasingly important to support efficiency and effectiveness in various sectors, making it a key component in future economic and social development. [7]

### **2.6. Guest Friendly**

"Guest-friendliness" in a robot refers to the robot's ability to interact with guests politely, provide a warm welcome, and provide necessary assistance or services in an efficient and pleasant manner. Guest-friendly robots are created to ensure a positive experience for users, so that they feel comfortable and appreciated while interacting with the robot. Guest-friendliness is an attitude, behavior or action carried out by an individual to respect and respect other people around him.

### **2.7. Front office services**

Front office service is the process of providing direct services to the public in an area that is easy to reach, namely the Front Office. Here, concierges interact directly with guests to meet their needs, provide information, and assist with various requests. The goal is to make the guest experience positive and efficient.

### **2.8. Internet of Things (IoT)**

IoT is a fundamental concept that allows various devices to connect with each other. This includes household appliances such as refrigerators, televisions, washing machines, lamps, smartphones and cars. In addition, IoT can also connect more complex machine components such as aircraft jet engines and drills for oil mining, and much more. [8]

### **2.9. Microcontroller**

A microcontroller is a small, fully functional computer system on a single chip. Inside there is a processor core that carries out program instructions, as well as memory that includes a small amount of RAM for temporary data storage and program memory that stores instructions to be executed. Microcontrollers are also equipped with input and output devices that enable interaction with other devices and the surrounding environment. Input devices can be sensors that detect changes in the environment, while output devices can be actuators that carry out actions based on instructions received. Microcontrollers are used in a wide range of applications, from consumer electronic devices to industrial control systems, because they are capable of carrying out specific tasks with high efficiency.[9]

## 2.10. Ultrasonic Sensors

Ultrasonic sensors are a type of sensor that functions to convert physical quantities (sound) into electrical quantities and vice versa. Ultrasonic waves are sound waves with a frequency above 20,000 Hz, so they cannot be heard by the human ear. Nevertheless, ultrasonic waves have various applications in technology. Ultrasonic waves can propagate through various media, such as solids, liquids and gases. The reflectivity of ultrasonic waves on the surface of a solid is almost the same as the reflectivity on the surface of a liquid. This allows ultrasonic sensors to measure distances or detect objects with a high degree of accuracy.[10]

## 2.11. Jumper Cables

Jumper cables are electrical cables used to connect various components on a breadboard without requiring soldering. These jumper cables usually have connectors or pins at both ends. The connector used to insert the pin is called a male connector, while the connector that accepts the pin is called a female connector. Jumper cables are divided into three types based on the connector combination: Male to Male, Male to Female, and Female to Female.

## 2.12. DF MP3 Player

DF Player Mini is a serial MP3 module that offers seamless integration for MP3 and WMV hardware decoding. From the software side, this module supports the use of TF cards and is compatible with FAT16 and FAT32 file systems. With simple serial commands, this module allows setting music playback and other functions without complicated operations. This module is easy to use, stable and reliable, which are its main features. In addition, this module can also function as a standalone device using only batteries.[11]

## 2.13. Ohm Speakers

A speaker is a transducer that converts electrical signals into sound by producing vibrations in its components, which are generally in the form of a membrane. Transducer itself refers to a device that converts one form of energy into another form of energy, including pressure sensors. Transducers can be electronic, electromagnetic, photovoltaic, electromechanical and photonic circuits or devices. Broadly speaking, transducer can also refer to an electronic device that converts one type of signal into another type of signal.

## 2.14. Breadboard

Breadboard is a board designed to facilitate the process of assembling electronic prototypes without requiring soldering of the components. With the use of a breadboard, electronic components can be installed and removed easily, allowing them to be reused in various other projects. Breadboards are usually made of plastic with a surface filled with small holes, which allows users to connect various electronic components flexibly and efficiently. This tool has become very important in experimentation and development of electronics projects, as it provides high flexibility and saves time in the assembly and testing process.[12]

## 2.15. Servo Motors

Servo motors are a type of electric motor equipped with a closed feedback system. In this system, the motor position is continuously informed back to the internal control circuit contained in the servo motor. A servo motor consists of several important components, namely a DC motor, a series of gears, a potentiometer, and a control circuit. These components work together to ensure that the motor can reach and maintain the desired position with high precision.[13]

## 2.16. LCD 4x20 i2c

LCD (Liquid Crystal Display) is a type of display commonly used in microcontroller projects, mainly because of its ability to work with low power consumption. These screens display information visually to the user in the form of characters, numbers, letters, or even simple graphics. LCDs are ideal for applications where energy efficiency and display clarity are priorities. In microcontroller-based systems, LCDs are used to provide direct feedback to users, such as displaying operating status, measurement results, or instruction messages, so that users can interact and monitor the system easily. These displays are available in a variety of sizes and configurations, from simple alphanumeric displays to more complex graphic displays, allowing for flexibility in user interface design. [14]

I2C is an interface protocol developed by Philips Semiconductor, which allows bidirectional communication between ICs using two cables. This protocol allows the system to connect up to 128 different devices with just two lines, one for serial clock (SCL) and one for serial data (SDA). Each device connected via I2C has a unique address that can be accessed in hardware using the master/slave protocol. Each slave device has an address, and the master device can choose which slave to receive or send data to. [15]

## 2.17. Keypads

Keypad is one of the interface devices that is often used in microcontroller systems, especially in the form of 4x4 or 3x4 matrix keypads. This keypad functions as an input tool that allows users to enter data or commands into the system. With a matrix configuration, the buttons on the keypad are connected in rows and columns, so that the microcontroller can detect which button is pressed using the combination of rows and columns. The use of keypads is very common in a variety of applications, from security systems, such as access codes, to everyday electronic devices, such as ATM machines, telephones and smart home devices. Flexibility and ease of integration make keypads an efficient and effective choice for various data input needs on microcontroller systems. [16]

## 2.18. 5V 2A Adapter

An adapter is a device that functions to convert high AC voltage to low DC voltage. This adapter acts as an alternative to DC voltage sources such as batteries, because AC voltage is longer lasting and can be used by anyone. We know that the electricity we use at home, offices and other places comes from PLN (State Electricity Company) which is distributed in the form of alternating current (AC). [17]

## 3. Analysis And Design

### 3.1. Research Methodology

In this research, the author uses a prototype method which is based on the concept of observation. This method includes data collection through direct observation and analysis of research objects at STMIK Kaputama and their environmental conditions. This process includes identifying the site specifications required for implementation of the planned system.

### 3.2. Problem Analysis

Campuses need to improve front office services to create something memorable for guests, especially in terms of reception. The quality of this service is very important to reflect a positive image of the campus and provide a good first impression to guests, prospective students, parents and other visitors. Front office staff are often limited in number and ability to handle all guests at the same time, especially during peak hours or large events such as new student registration, graduation, or other campus activities. These limitations can result in long queues, service delays, and less than satisfactory experiences for guests. To overcome this challenge, campuses can consider various innovative strategies and solutions. One of them is the application of technology, such as the use of IoT-based guest-friendly robots. This robot can help in welcoming guests. Overall, by improving front office services through a combination of technology and increasing staff capacity, campuses can create a friendlier and more efficient environment, increase guest satisfaction, and strengthen the positive image of the campus in the eyes of visitors.

### 3.3. System Requirements Analysis

Analysis of system requirements needed to create this system includes two main aspects: hardware and software.

1) The hardware and tools used in this research are as follows:

- a) Ultrasonic Sensor
- b) Servo Motor
- c) Jumper Cables
- d) Breadboard
- e) 4 Ohm Speakers
- f) DF MP3 Player
- g) ESP32
- h) 5V 2A adapter
- i) 3x4 Keypad
- j) LCD 4x20 i2c

2) The software that will be used in this research is as follows:

- a) Arduino IDE
- b) Microsoft Word
- c) Fritzing
- d) Mendeley
- e) Thinkable

### 3.4. System Working Principles

This guest-friendly robot works by detecting the presence of guests using an ultrasonic sensor, which then sends a signal to the ESP32. Once a guest is detected, the robot will play a welcome message via the DF MP3 Player connected to the speaker. Next, the robot offers guests the option to select a button. The available buttons are buttons 1, 4, 6 and 7 on the 3x4 keypad. Information options will be displayed on the LCD screen by displaying 4 information options, namely:

1. Study Program Available
2. Library Location
3. Campus Facilities
4. Service Time

And the appropriate information will be played through the speakers. All components are powered by a 5V 2A adapter, and connections between components are facilitated by jumper cables and breadboards for circuit flexibility.

### 3.5. System Block Diagram

The circuit block diagram is one of the crucial components in designing a device. Block diagrams are visual representations of system workflows used to depict actions in complex systems. These diagrams function at a higher level, providing a general overview of the system concept without diving into technical implementation details. Block diagrams help in understanding the relationships between the various components and processes in the system, and provide clear conceptual guidance even though they do not outline specific details about how each part will be implemented. [19](Fauzan et al., 2022)

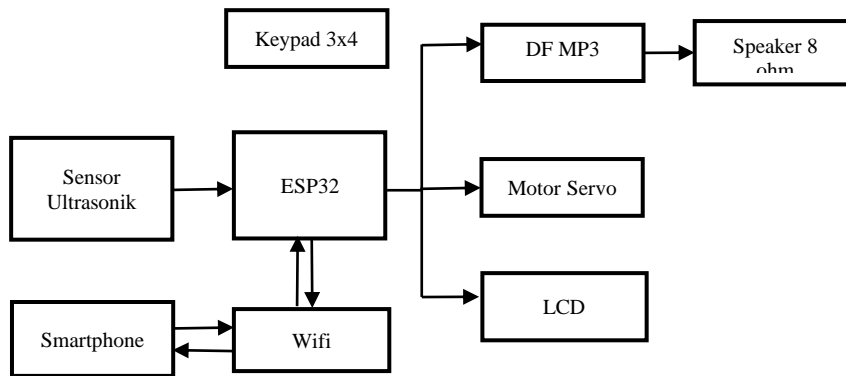

Fig. 1: System Block Diagram

### 3.6. Overall Design of the Tool

This section discusses the entire design process of the tool used in the project, including the selection and arrangement of the components involved, and how they work together to achieve the tool's purpose, namely welcoming guests and providing information.

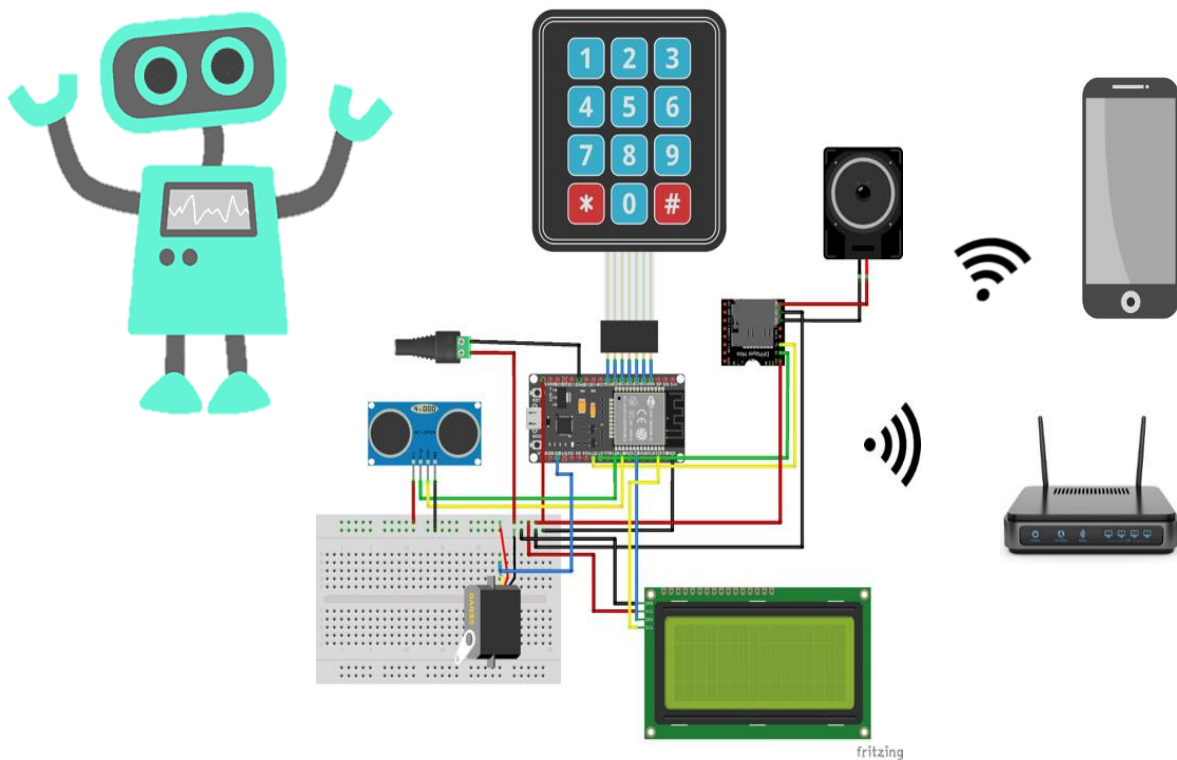
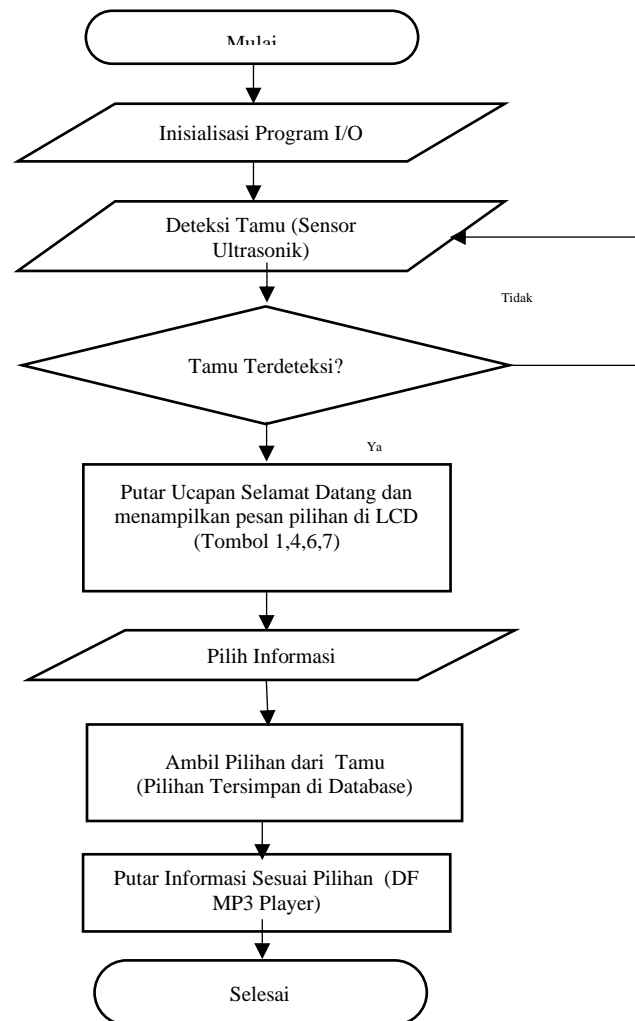

Fig. 2: Overall Design of the Tool

### 3.7. Circuit Flowchart

Device design begins by creating a flowchart (flow diagram) which aims to facilitate planning and programming on the microcontroller. Making this flowchart is designed to help understand the tool's working process better.



**Fig. 3:** Flowchart

#### Information:

1. Start: The process starts when the robot is turned on.
2. I/O Program Initialization: The robot initializes all necessary input and output, such as sensors, motors, and LCD screens, so that it is ready for use.
2. Guest Detection (Ultrasonic Sensor): The robot uses an ultrasonic sensor to detect the presence of guests nearby.
3. Guest Detected? Here, the robot checks if any guests are detected. If yes, the robot moves on to the next step; otherwise, the robot returns to the guest detection step.
4. Play the Welcome Greeting and Display Selected Messages on the LCD. Once the guest is detected, the robot greets you and displays information options on the LCD screen which can be selected by the guest by pressing the available buttons, namely buttons 1, 4, 6 and 7.
5. Select Information: Guests have the opportunity to select the information they want to hear by pressing one of the available buttons.
6. Take Choices from Guest (Stored Choices in Database): The robot records the choices made by the guest and stores them in the database for later reference.
7. Play Information According to Choice (DF MP3 Player): The robot uses DF MP3 Player to play information selected by the guest based on the choices that have been saved.
8. Finish: The process ends after the information is played, and the robot is ready to detect the next guest.

### 3.5. Links and bookmarks

All hypertext links and section bookmarks will be removed from papers during the processing of papers for publication. If you need to refer to an Internet email address or URL in your paper, you must type out the address or URL fully in Regular font.

## 4. Discussion And Implementation

### 4.1. Discussion

In this chapter, the process of designing a guest-friendly robot prototype for front office services at the STMIK Kaputama Binjai campus is discussed. This chapter includes an explanation of the components used, such as the ultrasonic sensor, ESP32, LCD 4x20, and DF MP3 Player, as well as how the designed system works. Apart from that, it also explains the integration of the Internet of Things (IoT) to control the robot via the Thinkable application and store guest interaction data in Firebase. This chapter provides a complete overview of how robots are implemented to improve efficiency and quality of service in campus front offices. The expected result of this tool is the creation of a more efficient and modern guest reception system at the front office of the STMIK Kaputama campus. By using robots equipped with Internet of Things (IoT) technology, it is hoped that the guest welcoming process will become more automatic, interactive and informative. This tool is expected to reduce the workload of front office staff, provide accurate and fast information to guests, and improve the campus' image as an innovative and high-tech institution.

In this research, several electronic components are used to build a guest-friendly robot that functions in the campus front office. The following is a brief explanation of each component:

1. Ultrasonic Sensor Uses ultrasonic waves to detect the presence of approaching guests. This sensor measures the distance of an object by emitting sound waves and measuring the time required for them to be reflected back.
2. Servo motors are used to move certain parts of the robot, such as moving the robot's hand to give a speech.
3. Jumper Wires Connecting cables used to connect various electronic components on the breadboard and microcontroller.
2. Temporary circuit board breadboard used to assemble electronic components without having to solder.
3. 4 Ohm Speaker is used to produce sounds, such as welcome greetings and information selected by guests.
4. DF MP3 Player MP3 player module used to play audio files that contain information or welcome messages.
5. ESP32 Microcontroller with WiFi and Bluetooth connection capabilities, used as the brain of the robot which controls all components and manages connections to the internet.
6. 5V 2A Adapter Power supply used to provide stable and sufficient electricity for all robot components.
7. The 3x4 keypad is used by guests to select the desired information by pressing buttons 1-4.
8. 4x20 LCD i2c display screen used to display information messages and options to guests. This LCD can display 4 lines of text with 20 characters in each line.

Apart from hardware components, this research also involves various software components to operate the guest-friendly robot. The following is a brief explanation of the software components used:

1. Arduino IDE A software development environment used to write, test, and upload code to the ESP32 microcontroller. Arduino IDE provides various libraries and tools that make it easier to develop microcontroller applications.
2. Thinkable Application development platform used to create drag-and-drop based mobile applications. Thinkable allows users to create applications that interact with robots over an internet connection, providing an easy-to-use user interface for controlling and monitoring robots.
3. Firebase Backend platform-as-a-service used to store and manage data. Firebase is used to store information selected by guests and provides a real-time database service that allows instant data synchronization between mobile applications and robots.
4. ESP32 Library A collection of libraries used in the Arduino IDE to program and control the ESP32 microcontroller. This library provides important functions for accessing WiFi, Bluetooth, and various sensors connected to the ESP32.
5. Ultrasonic Library, Library used to control ultrasonic sensors and read distance data measured by the sensor.
6. Servo Library, a library used to control the movement of servo motors, allowing you to easily adjust the servo position.
7. LiquidCrystal I2C Library: Library used to control the 4x20 i2c LCD, making it easier to display messages and information on the LCD screen.
9. DFRobotDFPlayerMini Library, Library used to control the DFPlayer Mini MP3 module, allowing easy setup and playback of audio files.

With this combination of hardware and software components, robots can function optimally to welcome guests, provide information, and store interaction data in a database that can be accessed and managed in real-time.

### 4.2. Software Testing

Software testing is an important step in the development process, ensuring the quality and effectiveness of the system being built. In software testing, various approaches and strategies will be discussed to test software developed with the Arduino IDE. The purpose of testing is to ensure that the code uploaded to the microcontroller works according to the design plan and to identify and correct potential errors that could affect overall system performance. In addition, this software testing will discuss how testing can ensure compatibility between components, evaluate system performance and stability, and improve user experience. With a comprehensive testing approach, it is hoped that the software developed can function optimally and meet user needs in real applications.

In implementing software testing, there are several stages that need to be considered, including:

- 1) The first step to take is to run the Arduino IDE application, then it will display a display as seen in Figure 4 :

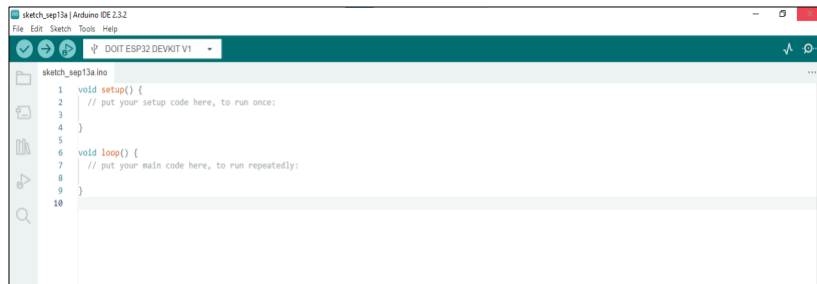

Fig. 4: Arduino IDE software

- 2) To connect the ESP32 to the Arduino IDE, the next step is to connect the ESP32 to the computer's USB port using a USB cable, then open the Board Manager in the Arduino IDE. After that, search for and select "DOIT ESP32 Devkit V1" as the board used. This option will configure the IDE to support ESP32 microcontroller development and programming.

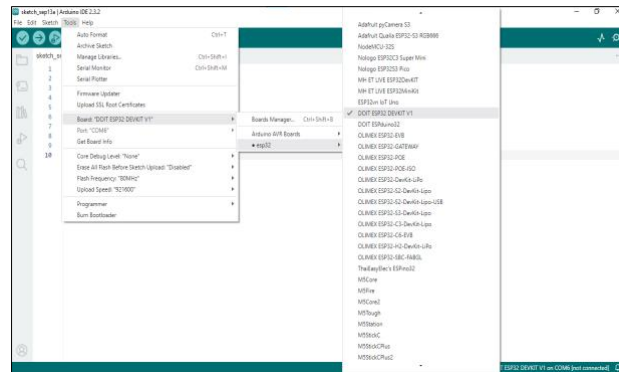

Fig. 5: Menu Tools Board Manager

- 3) The next step is to select the COM6 Port from the list of available ports to connect the IDE with the ESP32.

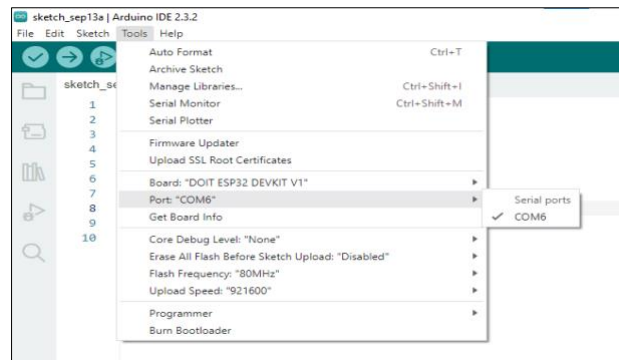

Fig. 6: Menu Tools Port "COM6"

- 4) Before the program is uploaded to the microcontroller, make sure to first save the program file that has been created. The file here is named ROBOT\_D34.

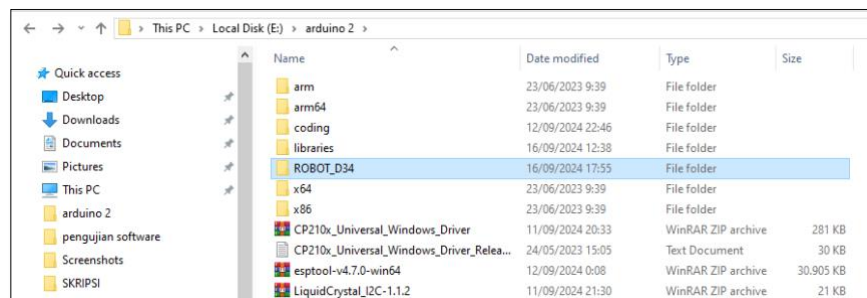

Fig. 7: Storage Files

- 5) The next stage is to compile the program to ensure that there are no errors. This process will show whether the program has been successful or there are still errors that need to be corrected. Once there is a statement done compiling then the program is successful.

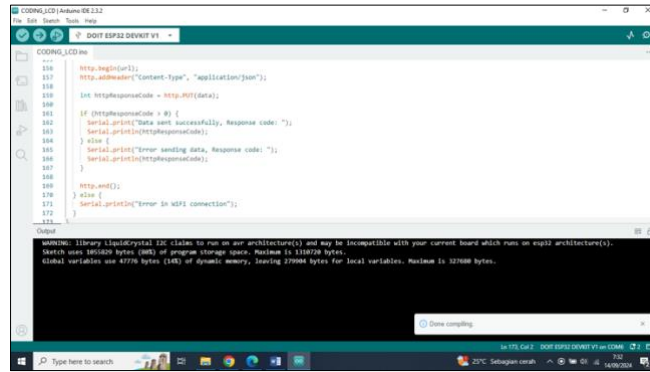

Fig.8: Done Compiling

- 6) After the program has been successfully compiled without errors, the next step is to upload the program to the microcontroller. This process ensures that the code that has been created can be executed on real hardware, so that the tool can function as planned. Wait for the process to reach 100% so that it runs properly and correctly. The successful upload display can be seen in the image.

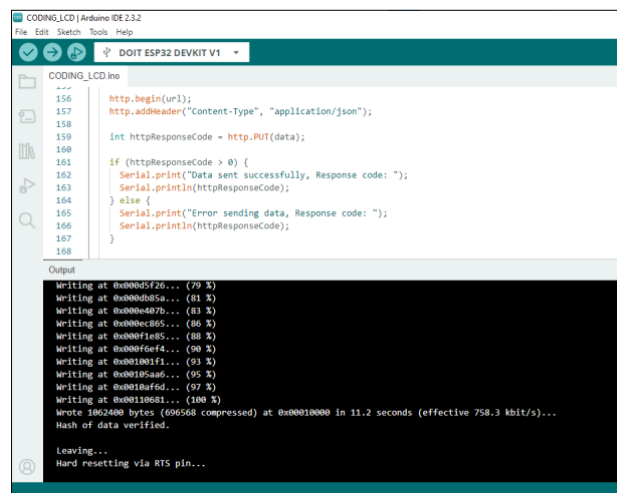

Fig. 9: Uploaded Successfully

### 4.3. Hardware Testing

Hardware testing is an important stage in the development of microcontroller-based systems such as the ESP32. This process aims to ensure that all physical components, such as sensors and other elements, function properly and comply with the desired specifications. Testing is carried out by operating the hardware under actual conditions and verifying that the results obtained are as expected. In addition, this testing also helps identify and fix potential problems or errors in the hardware before the system is fully implemented.

### 4.4. Device Testing

Device testing is a process to evaluate and ensure that hardware functions properly according to established specifications. This involves testing the device under real-world conditions to verify its performance, stability, and functionality and to detect and correct problems before the device is widely used.



Fig. 10: Device Testing

#### 4.5. Hardware Device Test Results

After all components are assembled, the next step is to test the program and device to ensure that everything functions properly and runs as expected.

#### 4.6. ESP32 Microcontroller Testing

Next, carry out testing on the ESP32. This process involves verifying that the hardware is functioning properly and that the uploaded program code can be executed properly. This testing includes checking connectivity, testing functionality, and ensuring that output is as expected, as well as identifying and fixing problems that may arise during operation.

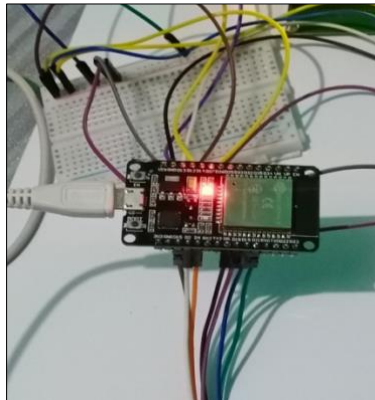

Fig. 11: ESP32 Microcontroller Testing

#### 4.7. 4x20 I2C LCD Testing

LCD 4x20 I2C testing aims to ensure that the LCD screen functions properly and is able to display information as expected. This testing process involves several important steps:

1. First, make sure all connections between the LCD and the microcontroller are correct and sturdy.
2. Then, install the required libraries such as LiquidCrystal\_I2C in the Arduino IDE.
3. After that, create and upload a program that displays messages or data on the LCD to verify the functionality of each row and column.

Observe the display results on the LCD and check whether there are any characters that do not appear or are not appropriate.

By carrying out this test, you can ensure that the 4x20 I2C LCD is ready for use.



Fig. 12: 4x20 I2C LCD Testing

#### 4.8. 4x3 Keypad Testing

The 4x3 keypad test aims to ensure that all the buttons on the keypad function properly and can send the correct input to the microcontroller.



Fig. 13: Keypad Testing

#### 4.6. Ultrasonic Sensor Testing

The ultrasonic sensor in this project functions to detect the presence of guests in front of the welcoming robot. Ultrasonic sensor testing aims to ensure that the sensor can measure distance accurately and provide appropriate output to the ESP32 microcontroller.

#### 4.7. Results of The Entire Series Of Tools

In this research, researchers designed and developed a guest welcoming robot based on the ESP32 microcontroller. The entire series of tools consists of several main components, namely an ultrasonic sensor to detect the presence of guests, a servo motor which functions to move the robot hand, a 4x20 I2C LCD to display information, a 4x3 keypad for input from visitors. And a DFPlayer Mini MP3 module to emit a welcome sound. The ultrasonic sensor will detect guests and activate the servo and sound playback via DFPlayer Mini. Additionally, data from interactions with the keypad will be sent to Firebase using a WiFi connection connected via the ESP32. All of these components work synergistically to create an interactive and informative guest welcoming experience.

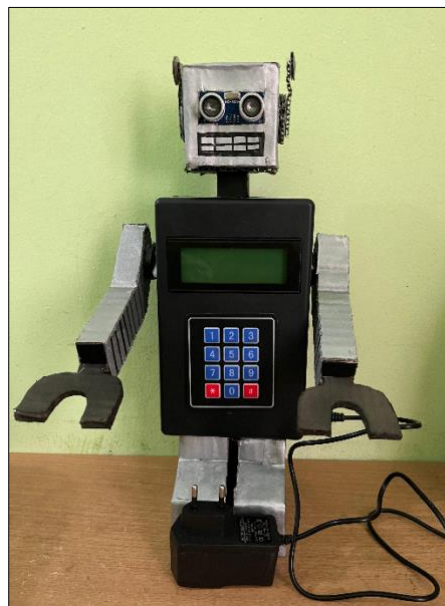

Fig. 14: Robot Series Results

## 5. Conclusions and Recommendations

### 5.1. Conclusion

The conclusions of this research are divided into three parts, namely:

1. The researcher succeeded in designing and implementing a guest welcoming robot based on the ESP32 microcontroller by equipping the robot with an ultrasonic sensor system to detect guests by moving its hand which is controlled by a servo motor, so that by integrating various components, this robot can provide a better welcoming experience and efficient in the campus environment.
2. The IoT system for controlling this guest-friendly robot can be controlled by turning off the control sensor remotely but still on a local scale. This system is also able to send interaction data to Firebase via a stable WiFi connection.

3. The features and functionality of the robot will be displayed via a 4x20 I2C LCD to display information, a 4x3 keypad for user input, and a DFPlayer Mini MP3 module to emit a welcome sound. Based on test results, this system is able to function according to the desired specifications.

## 5.2. Recommendations

For further development, there are several suggestions that can be considered:

1. For further development, researchers hope that in the future the guest-friendly robot control system will not only be local.
2. The robot should have an automatic control system for welcoming guests so that the robot is not only placed on the front office desk but can welcome guests directly with wider movements.

## References

- [1] Putro, M. D., & Litouw, J. (2017). Robot Pintar Penyambut Costumer pada Pusat Perbelanjaan Kota Manado. *Jurnal Rekayasa Elektrika*, 13(1), 8. <https://doi.org/10.17529/jre.v13i1.5901>
- [2] Lukman, A. M., & Santoso, P. (n.d.). Robot Penerima Tamu dengan Sistem Pengenalan Wajah dan Suara. *Seminar Nasional Fortei Regional*, 7.
- [3] Kusumah, H., & Pradana, R. A. (2019). Penerapan Trainer Interfacing Mikrokontroler Dan Internet of Things Berbasis Esp32 Pada Mata Kuliah Interfacing. *Journal CERITA*, 5(2), 120–134. <https://doi.org/10.33050/cerita.v5i2.237>
- [4] Sanjaya, M. W. S. (2016). *Panduan praktis membuat robot cerdas menggunakan Arduino dan MATLAB* (hal. 22). Andi.
- [5] Jilil Pascasarjana Magister Sistem Komputer STMIK Handayani Makassar Jl Adhyaksa Baru No, A. (2016). *Konferensi Nasional Ilmu Komputer (KONIK) 2016 RANCANG BANGUN ROBOT HUMANOID*.
- [6] Fahmi, H. Z., Maulana, R., & Kurniawan, W. (2017). Implementasi Complementary Filter Menggunakan Sensor Accelerometer dan Gyroscope pada Keseimbangan Gerak Robot Humanoid. *Pengembangan Teknologi Informasi Dan Ilmu Komputer*, 1(11), 1376–1384.
- [7] Saleh, K. (2019). Rancangan Perangkat Lunak Pengendali Robot Pemantau Berbasis Ponsel Pintar Android. *Saintek ITM*, 32(2), 11–15. <https://doi.org/10.37369/si.v32i2.56>
- [8] Selay, A., Andgha, G. D., Alfarizi, M. A., Bintang, M. I., Falah, M. N., Khaira, M., & Eneep, M. (2022). Karimah Tauhid, Volume 1 Nomor 6 (2022), e-ISSN 2963-590X. *Karimah Tauhid*, 1(2963-590X), 861–862.
- [9] Kusumah, H., & Pradana, R. A. (2019). Penerapan Trainer Interfacing Mikrokontroler Dan Internet of Things Berbasis Esp32 Pada Mata Kuliah Interfacing. *Journal CERITA*, 5(2), 120–134. <https://doi.org/10.33050/cerita.v5i2.237>
- [10] Sanjaya, M. W. S. (2016). *Panduan praktis membuat robot cerdas menggunakan Arduino dan MATLAB* (hal. 22). Andi.
- [11] Ratna, S. (2019). Air Mancur Otomatis Dengan Musik Berbasis Arduino. *Technologia: Jurnal Ilmiah*, 10(4), 179. <https://doi.org/10.31602/tji.v10i4.2359>
- [12] Tantowi, D., & Yusuf, K. (2020). Simulasi Sistem Keamanan Kendaraan Roda Dua Dengan Smartphone dan GPS Menggunakan Arduino. *Jurnal ALGOR*, 1(2), 9–15. <https://jurnal.buddhidharma.ac.id/index.php/alogor/article/view/302/209>
- [13] Mulyono Akmal, M. (2019). Simulasi Alat Penjaring Ikan Otomatis Dengan Penggerak Motor Servo Continuous, Sensor Jarak Hc-Sr04 Dan Tombol, Menggunakan Arduino Mega. *Jurnal Ilmiah Ekonomi Dan Bisnis*, 12(1), 39–47. <https://journal.stekom.ac.id/index.php/Bisnis/article/view/82>
- [14] Nurlana, M. E., Murnomo, A., & Abstrak, I. A. (2019). Pembuatan Power Supply dengan Tegangan Keluaran Variabel Menggunakan Keypad Berbasis Arduino Uno. *Jurnal Teknik*, 8(2), 53–59. <https://journal.unnes.ac.id/sju/index.php/eduel/article/view/27045>
- [15] Kusumah, H., & Pradana, R. A. (2019). Penerapan Trainer Interfacing Mikrokontroler Dan Internet of Things Berbasis Esp32 Pada Mata Kuliah Interfacing. *Journal CERITA*, 5(2), 120–134. <https://doi.org/10.33050/cerita.v5i2.237>
- [16] Rahajoeningroem, T. (2013). SISTEM KEAMANAN RUMAH DENGAN MONITORING MENGGUNAKAN JARINGAN TELEPON SELULAR Home Security System with Monitoring using Cellular Phone Network. *Januari*, 1(1), 24.
- [17] Kusumaningrum, N., & Fitriah, F. (2020). Perancangan Pembuatan Permen Kapas Otomatis Berbasis Arduino Uno. *TESLA: Jurnal Teknik Elektro*, 22(1), 12. <https://doi.org/10.24912/tesla.v22i1.7810>