



# A Smart Control System Model for Pharmaceutical and Medical Equipment Storage Using Fuzzy Logic and IoT

Didi Rahmat Saputra<sup>1\*</sup>, Fadhila Azzahra<sup>2</sup>, Lahuddin<sup>3</sup>, Ade Octaviansyah<sup>4</sup>

<sup>1,2,3,4</sup> Faculty of Computer Science, Ichsan Satya University

[didirahmat@gmail.com](mailto:didirahmat@gmail.com)<sup>1\*</sup>, [fadhilaazzahra310@gmail.com](mailto:fadhilaazzahra310@gmail.com)<sup>2</sup>, [emilahudacademy@gmail.com](mailto:emilahudacademy@gmail.com)<sup>3</sup>, [Ade.octav@gmail.com](mailto:Ade.octav@gmail.com)<sup>4</sup>

---

## Abstract

The primary goal of this study is to develop an innovative Smart Control System designed to maintain optimal temperature and humidity levels within a medical storage environment. By integrating Fuzzy Logic with Internet of Things (IoT) technology, we aim to **enhance/optimize** environmental control. Our experimental approach involved constructing an IoT-based prototype utilizing an Arduino Uno board equipped with high-precision temperature and humidity sensors, and DHT22 components for automated temperature and humidity stabilization. A fuzzy logic algorithm was **employed/utilized** to analyze real-time sensor data and **generate/produce** adaptive control outputs in response to environmental fluctuations. This smart control system is expected to **significantly enhance/make a significant contribution to** medical inventory management by reducing product damage and ensuring the safety of medical supplies. This research paves the way for future advancements in applying advanced technology for environmental control in healthcare settings

**Keywords:** Smart Control System, Fuzzy Logic, Internet Of Things (IoT)

---

## 1. Introduction

As chemical or biological substances, medications must maintain specific physicochemical properties to ensure their efficacy. Proper storage conditions are crucial for preserving these properties. Fluctuations in temperature and humidity can significantly impact the quality and potency of medications.

To address this, fuzzy logic can be employed to monitor and regulate the air quality and temperature within medication storage areas. Through IoT technology, data from DHT22 sensors can be collected in real-time and transmitted to a server or cloud for analysis. Fuzzy logic can then be used to process this data and provide a more accurate assessment of the environmental conditions. IoT enables the development of intelligent control systems.

The Internet of Things (IoT) revolutionizes how we interact with our environment by connecting devices and enabling data exchange. This leads to increased efficiency, automation, and data-driven decision-making in various fields.

Previous research has explored the development of automated systems using Node MCU ESP32 to control temperature and humidity, providing real-time data to technicians. Other studies have focused on IoT-based systems for monitoring pharmaceutical storage conditions, ensuring that temperature and humidity remain within specified limits.

This research aims to design and develop an innovative smart control system model that can maintain ideal temperature and humidity levels in medication and medical equipment storage areas by leveraging fuzzy logic and IoT technology. The expected outcome is a more efficient control system capable of adapting to daily patterns and providing enhanced sensing capabilities.

## 2. Research Methodology

### 2.1. The paper should have the following structure

This research focuses on the design of an intelligent system utilizing Internet of Things (IoT) technology. Researchers employ techniques to model an intelligent system capable of controlling and monitoring temperature and humidity within a pharmaceutical and medical equipment storage room. Additionally, this research evaluates the efficiency of the designed system. The discussion will cover methods for regulating temperature and humidity, as well as the significant impact of this system on the conditions within the pharmaceutical and medical equipment storage room

### 2.2. Internet of Things (IoT)

Internet of Things (IoT) is a network of physical devices connected and communicating over the internet. These devices, such as sensors, actuators, home appliances, vehicles, and industrial machines, could collect, share, and exchange data [8]. IoT is also defined as a network, where various devices are connected through different IP addresses and IDs, allowing them to communicate and exchange data about their surroundings. These devices can collect data from their environment, send it over the internet, and receive instructions or data back to enable smarter and more responsive decision-making [9]. Figure 1 shows the various components of the Internet of Things platform [10]. (Please incorporate images when they enhance the content or when they are requested.

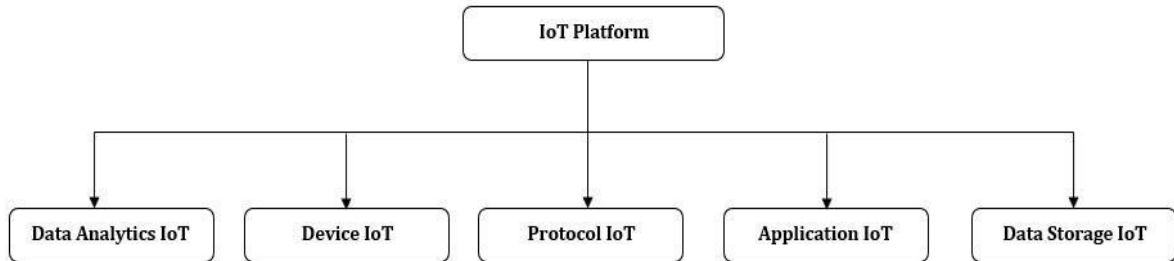

Fig. 1: IoT Platform Components

Simply put, the Internet of Things lets users communicate with hardware devices online. One example of this communication is the process of sending and receiving data from users to devices or vice versa [11]. In the future, IoT is expected to be more integrated into daily life to improve efficiency, security, and convenience. However, to ensure continued and secure progress, issues of cybersecurity and privacy must be addressed. Addressing these challenges will be crucial for realizing the full potential of the Internet of Things

### 2.3. Fuzzy Logic

Lotfi Zadeh, a renowned expert in mathematics and computer science, pioneered fuzzy logic, a revolutionary computational paradigm that enables the representation of uncertainty and ambiguity in data. Zadeh made significant contributions to the advancement of artificial intelligence and computational systems. Through his innovative work, he facilitated the development of more sophisticated algorithms and systems capable of handling complex and unstructured data, thus pushing the boundaries of traditional computation [12]. Professor Lotfi Zadeh of the University of California, recognized for introducing the concept of fuzzy sets to represent uncertainty in linguistic variables, developed fuzzy logic in 1965 [13].

Fuzzy logic is a mathematical technique employed to model human reasoning. It allows for the determination of uncertain values based on existing variables and applied inference rules [14].

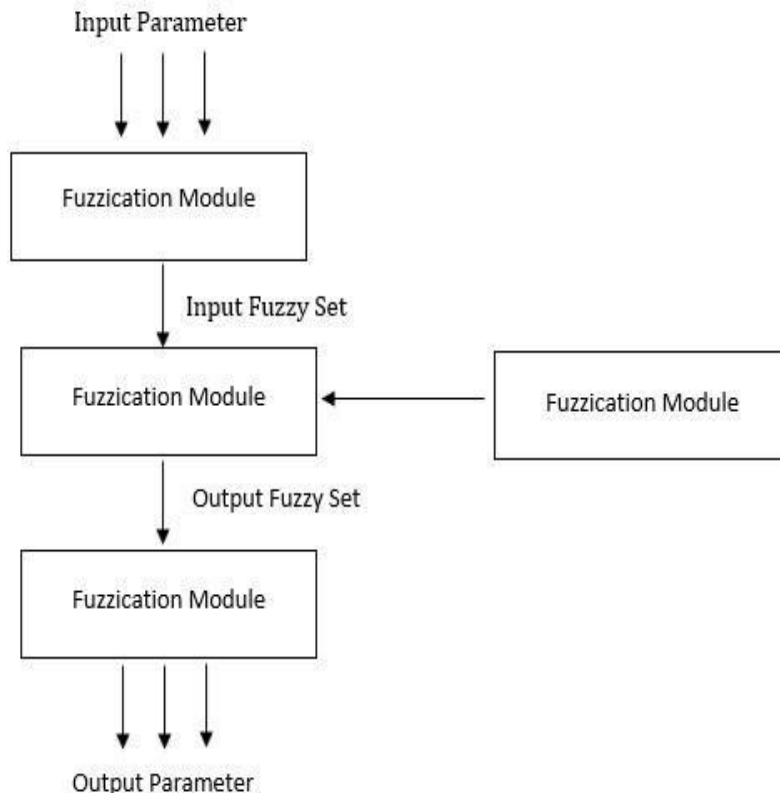

Fig. 2: Fuzzy System Model

## 2.4. Arduino Uno



Fig. 3: Arduino

Arduino is an open-source hardware prototyping platform that is easy to use for starting programming-based projects. Apart from functioning as a developer tool, Arduino is also a combination of hardware, programming language, and IDE (Integrated Development Environment) [15].

The most popular Arduino board worldwide is probably the UNO. The Arduino Uno board is very popular because it is powered by an Atmega328 processor operating at 16 MHz. Although its 32 KB program memory, 1 KB EEPROM, and 2 KB RAM means it doesn't have the most storage space, users seem to like it and still use it frequently. However, the downside lies in the fact that there are only 14 digital I/Os, 6 analog inputs, and 5 V and 3.3 V power rails [16].

## 3. Research Context

Several block diagrams and flowcharts will be used to illustrate the design of a smart control system model. To meet the initial design requirements, several modules will be added to this Arduino. For example, there is a relay that turns electrical devices on and off, an RTC module that generates real-time data on the device, a current sensor that measures the amount of power used, and an LCD that can view and display status and power information. This is an illustration of a block diagram:

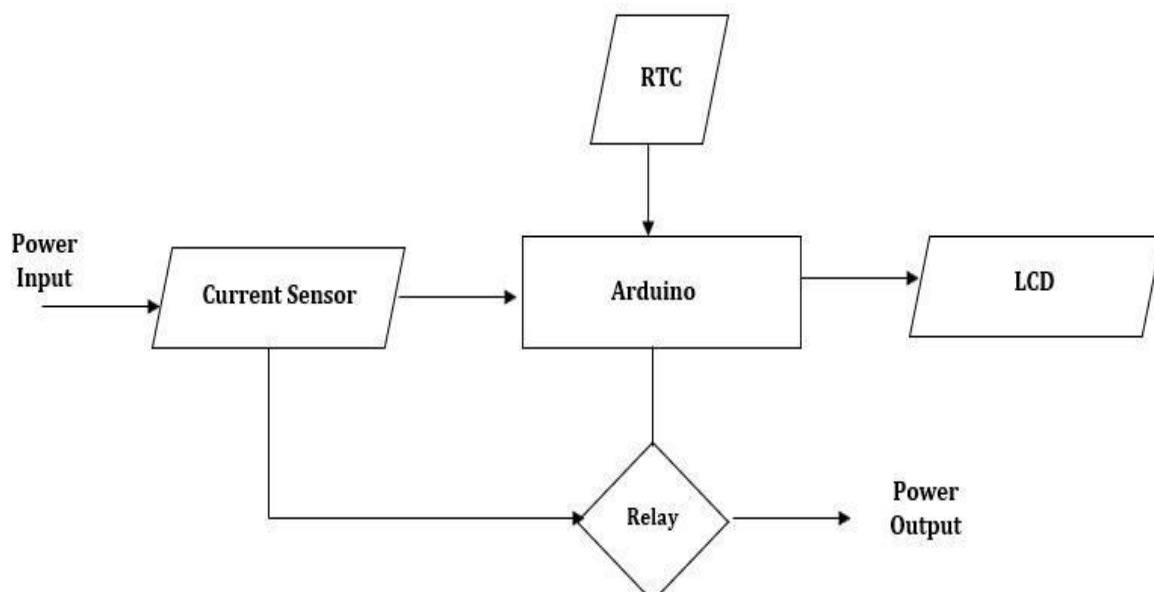

Fig. 4: Relay Module Block Diagram

The Arduino Uno will then be used to implement the fuzzy logic method after being developed, and of course, the sensor that will be used is already connected to the Arduino Uno.

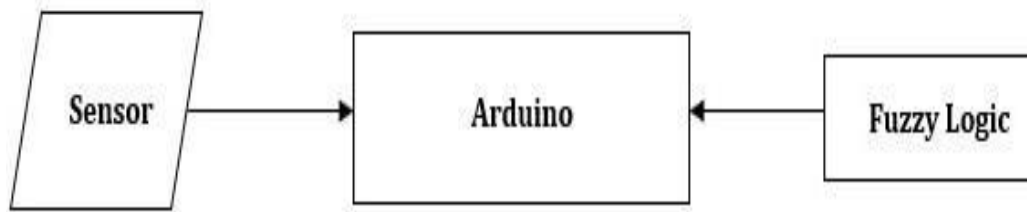

Fig. 5: Sensor Block

The next step in developing this smart system involves connecting these modules to the internet (Google Cloud SQL) to store data in a database on the server. This data can be accessed through a program on the web server that is part of the system, so the information received will also appear on computers and mobile phones

### 3.1. Network topology diagram

The diagram presents an overall network topology diagram, illustrating the interconnectedness of various modules within the smart system. Here's a detailed breakdown of the steps involved:

1. Data Collection by Sensors: Depending on the specific sensors employed, data such as temperature, humidity, air quality, or other environmental parameters are gathered.
2. Data Transmission to Databases:
  - a. The data collected is forwarded to two types of databases:
    - i. On- premises (local) database: This database is physically located within the system's environment.
    - ii. Google Cloud SQL: This cloud-based database offers remote storage and accessibility.
  - b. The dual storage approach provides flexibility and redundancy, always ensuring data safety and accessibility.
3. Data Access and Visualization: A program running on a web server, integrated into the smart system, enables users to access data stored in both databases.
4. The web server processes and displays the data in a user-friendly format, allowing users to view and interact with the system via computers or mobile devices.
5. Real-time access enables users to monitor and control the smart system from various devices.

## 4. Conclusion

The study sought to design an innovative IoT-based smart control system employing fuzzy logic and an Arduino Uno to ensure optimal storage conditions for pharmaceuticals and medical devices. The primary objective was to enhance the efficiency and efficacy of medication storage. This research represents an ongoing endeavor in this field.

## References

- [1] M. A. Paredes-Valverde, G. Alor-Hernández, J. L. García-Alcaráz, M. Del P. Salas- Zárate, L. O. Colombo-Mendoza, And J. L. Sánchez-Cervantes, "Intellihome: An Internet Of Things-Based System For Electrical Energy Saving In Smart Home Environment," *Comput Intell*, Vol. 36, No. 1, Pp. 203–224, Feb. 2020, Doi: 10.1111/Coin.12252.
- [2] M. Kashyap, V. Sharma, And N. Gupta, "Taking Mqtt And Nodemcu To Iot: Communication In Internet Of Things," In *Procedia Computer Science*, Elsevier B.V., 2018, Pp. 1611–1618. Doi: 10.1016/J.Procs.2018.05.126.
- [3] S. K. Malchi, S. Kallam, F. Al-Turjman, And R. Patan, "A Trust-Based Fuzzy Neural Network For Smart Data Fusion In Internet Of Things," *Computers And Electrical Engineering*, Vol. 89, Jan. 2021, Doi: 10.1016/J.Compeleceng.2020.106901.
- [4] A. De Paola, P. Ferraro, G. Lo Re, M. Morana, And M. Ortolani, "A Fog-Based Hybrid Intelligent System For Energy Saving In Smart Buildings," *J Ambient Intell Humaniz Comput*, Vol. 11, No. 7, Pp. 2793–2807, Jul. 2020, Doi: 10.1007/S12652-019-01375-
- [5] A. A. M. Khalifa And K. Prawiroredjo, "Model Sistem Pengendalian Suhu Dan Kelembaban Ruang Produksi Obat Berbasis Nodemcu Esp32," *Jurnal Eltikom*, Vol. 6, No. 1, Pp. 13–25, Jan. 2022, Doi: 10.31961/Eltikom.V6i1.415.
- [6] F. Akbar And S. Sugeng, "Implementasi Sistem Monitoring Suhu Dan Kelembapan Ruang Penyimpanan Obat Berbasis Internet Of Things (Iot) Di Puskesmas Kecamatan Taman Sari Jakarta Barat," *Jurnal Sosial Teknologi*, Vol. 1, No. 9, Pp. 1021–1028, 2021.
- [7] S. U. Filla And S. Suhardi, "Prototype Alat Pengatur Temperatur Ruang Kerja Pada Rumah Menggunakan Logika Fuzzy Tsukamoto Berbasis Iot," *Journal Of Science And Social Research*, Vol. 7, No. 1, Pp. 68–77, 2024.
- [8] M. Raval, S. Bhardwaj, A. Aravelli, J. Dofe, And H. Gohel, "Smart Energy Optimization For Massive Iot Using Artificial Intelligence," *Internet Of Things (Netherlands)*, Vol. 13, Mar. 2021, Doi: 10.1016/J.Iot.2020.100354.
- [9] F. D. Silalahi *Et AL*, "Implementasi Internet Of Things (Iot) Dalam Monitoring Suhu Dan Kelembaban Ruang Produksi Obat Non Steril Menggunakan Arduino Berbasis Web," Vol. 13, No. 2, Pp. 62–68, 2021.
- [10] M. Wimala And D. K. Imanuela, "Perkembangan Internet Of Things Di Industri Konstruksi," *Journal Of Sustainable Construction*, Vol. 1, No. 2, Pp. 43–51, [Online]. Available: <https://journal.unpar.ac.id/index.php/josc>
- [11] Anggy Giri Prawiyogi And Aang Solahudin Anwar, "Perkembangan Internet Of Things (Iot) Pada Sektor Energi : Sistematis Literatur Review," *Jurnal Mentari: Manajemen, Pendidikan Dan Teknologi Informasi*, Vol. 1, No. 2, Pp. 187–197, Jan. 2023, Doi: 10.34306/Mentari.V1i2.254.
- [12] A. Khudoyberdiev, S. Ahmad, I. Ullah, And D. H. Kim, "An Optimization Scheme Based On Fuzzy Logic Control For Efficient Energy Consumption

- In Hydroponics Environment,” *Energies (Basel)*, Vol. 13, No. 2, 2020, Doi: 10.3390/En13020289.
- [13] F. Elfaladonna, I. Griha, And T. Isa, “Uji Efektifitas Metode Fuzzy Logic Mamdani Pada Penerimaan Beasiswa Bantuan Menggunakan Matlab,” *Science And Information Technology (Sintech)*, Vol. 3, 2020, [Online]. Available: <https://doi.org/10.31598>
- [14] A. N. Shahbaz, H. Barati, And A. Barati, “Multipath Routing Through The Firefly Algorithm And Fuzzy Logic In Wireless Sensor Networks,” *Peer Peer Netw Appl*, Vol. 14, No. 2, Pp. 541–558, Mar. 2021, Doi: 10.1007/S12083-020-01004-2.
- [15] I. D. M. J. Putra, I. Sulistiyowati, And S. Syahririni, “Hot Water Looping System To Control Temperature Of Drug Production Based Arduino,” *Seminar Nasional & Call Paper Fakultas Sains Dan Teknologi (Senasains)*, Vol. 2, No. 2, 2022.
- [16] H. K. Kondaveeti, N. K. Kumaravelu, S. D. Vanambathina, S. E. Mathe, And S. Vappangi, “A Systematic Literature Review On Prototyping With Arduino: Applications, Challenges, Advantages, And Limitations,” *Computer Science Review*, Vol. 40. Elsevier Ireland Ltd, May 01, 2021. Doi: 10.1016/J.Cosrev.2021.100364.